

YB5500 Series

product guide

features

- 2 models ...
 - YB5515: 15.0T (13.6mt) 3-section boom with 41 ft. 0 in. (12.5m) outreach
 - YB5518: 18.0T (16.3mt) 4-section boom with 54 ft. 6 in. (16.6m) outreach
- 15 ft. (4.6m) offsettable swingaway extension
- 20,000 lb. (9 072kg) deck carrying capacity
- 101 bhp (75.3 kW) GM EFI dual fuel engine or 110 bhp (82.0 kW) Cummins diesel engine



Industrial Hydraulic Crane

contents

Features	2
Specifications	3
YB5515	
Dimensions	5
Working Range	6
Load Chart	8
Load Chart	9
YB5518	
Dimensions	10
Range Diagram	11
Load Chart	12
YB5515 (metric)	
Range Diagram	13
Range Diagram	14
DIN/ISO Load Chart	15
DIN/ISO Load Chart	16
YB5518 (metric)	
Range Diagram	17
DIN/ISO Load Chart	18

features

2



- Single position oblique style outriggers (YB5515).
- -2-position beam / jack style outriggers (YB5518).



Standard:

- G.M. V-6 EFI 4.3 L Dual-Fuel engine rated @ 101 bhp (75.3kw) @ 2500 r.p.m.



Standard: Open air cab shell w/overhead safety glass

Optional: Closed cab with hinged door, heater, and defroster



Standard: 41 ft. (12.5m) main boom on the YB5515
54 ft. 6 in. (16.6m) main boom on the YB5518

Optional: YB5515: Manual 4th main boom section adds 11 ft. (3.4m) additional main boom length



Standard: 4-wheel steer (YB5515)

Optional: 2-wheel, -4-wheel, and crab steer with electronic self-alignment (**std. on YB5518**)

specifications

3

Superstructure

Boom

YB5515: 18 ft. 6 in. – 41 ft. 0 in. (5.6m – 12.5m) three-section full power boom.

Maximum tip height: 46 ft. 3 in. (14.1m)

YB5518: 18 ft. 6 in. – 54 ft. 6 in. (5.6m – 16.6m) four-section full power boom.

Maximum tip height: 56 ft. 2 in. (17.1m)

*Optional Boom

YB5515: Manual 4th main boom fly section

Maximum tip height: 52 ft. 3 in. (15.9m)

*Boom Extension

15 ft. (3.6m) offsettable swingaway extension

Boom Nose

YB5515: 2 sheave non-pivoting boom nose

YB5518: Two sheave, -3-position (0°, +40°, +80°) pivoting boom nose for minimizing head space requirements. Lowers head height 15.9 in. (0.4m) when nose is pivoted fully forward.

Boom Elevation

YB5515: Single double acting hydraulic cylinder with integral holding valve.

YB5518: Two double acting hydraulic cylinders with integral holding valve.

Elevation: 0° to 69° for the YB5515

0° to 80° for the YB5518

Anti-Two Block Device

Standard anti-two block device, when activated, provides an audible and visual warning to the crane operator and disengages all crane functions whose movement can cause two-blocking.

Load Indicator

A simple effective and easy to use load indicating system used in conjunction with the anti-two block system to assist the operator in efficient operation of the unit within the limits of the load chart. The display panel displays the hook load and warns the operator when a preset load capacity is exceeded. The warning is by a flashing light on the display panel. In conjunction with the load display panel (receiver), there is a wireless transmitter and load sensing pin attached to the boom head that transmits the hook load to the display panel.

*Rated Capacity Limiter (RCL)

Similar to the Load Indicator, but stops the telescope out and boom lift down function when a load limit is exceeded. Uses a similar display panel with the addition of displaying boom angle and boom length read outs on the panel.

*Load Moment Indicator (LMI)

Digital display of boom angle, boom length, boom radius, capacity, and allows for operator input to set the limits based on load chart. Displays color coded light bar and audible alarm with function cutout if load exceeds entered parameters.

Swing

Ball bearing swing circle with 360° continuous rotation.

Hydraulic driven worm gear and pinion.

Maximum speed: YB5515: 2.1 rpm

YB5518: 2.5 rpm

Hydraulic System

4 section gear pump providing a system pressure of 3500 psi (241.3 bars)

Combined flow: 88.0 gpm (333.1 Lpm)

YB5515: Six section valve bank mounted in dash with direct mechanical linkage for low effort lever control.

YB5518: Six section valve bank chassis mounted; operated via dash mounted, pilot pressure hydraulic joysticks.

Return line filter with full flow by-pass protection and service indicator.

40 gallon (151.4 L) hydraulic reservoir with sight level gauge and steel side plating to guard against side impact damage.

Hoist Specifications

Piston motor drive with spring applied / hyd. released brake. Equal speed power up and down.

Drum Diameter: 9.75 in. (0.25m)

Maximum hoist single line pull: 12,000 lb. (5 443kg)

Maximum hoist single line speed:

YB5515: 126 FPM (38.4m / min)

YB5518: 158 FPM (48.2m / min)

Maximum Permissible Single Line Pull:

YB5515: 7,500 lb (3 402kg)

(1/2" [12.7mm] EEIPS)

YB5518: 9,000 lb (4 082kg)

(1/2" [12.7mm] Python Ultra)

Rope Length:

YB5515:

(3-section boom) 240 ft. (73.0m)

(4-section boom) 290 ft. (88.4m)

YB5518: 310 ft. (94.5m)

*Denotes optional equipment

YB5500 Series

GROVE

Courtesy of Crane.Market

specifications

4

Carrier

Frame

High strength alloy steel constructed with integral outrigger housings; front and rear tie-down lugs. 75 ft.² carrydeck size with 20,000 lb (9 072kg) carrying capacity. Deck coated with anti-skid treatment.

Outriggers

YB5515: Front and rear oblique type beams at all four corners with integral holding valves. Outrigger pads form an integral part of the beam.

YB5518: 2-stage hydraulic telescoping beam with oblique type jack on all four corners, provides extended and down and retracted and down lifting capacities. Integral holding valves on both beam and jack.

Outrigger Controls

YB5515: Lever controls located on dash panel and operate the beams in pairs from side to side. Level bubble located inside operators compartment.

YB5518: Two switch operation mounted on dash panel. One 3-position rocker switch to select all beams / jacks, left beams / jacks only, or right beams / jacks only. Separate 4-way toggle switch to activate beams out / in and jacks down / up. Level bubble indicator located inside operators compartment.

*Independent outrigger controls available as an option.

Std. Engine

G.M. 4.3L V-6 EFI dual fuel (gasoline / L.P.) rated @ 101 bhp (75.3kW) @ 2500 rpm.

*Optional Engine

YB4415: Cummins 4B 3.3L turbo-charged diesel rated @ 85 bhp (63.4kW) @ 2500 rpm.

YB5518: Cummins QSB4.5L turbo-charged diesel rated @ 110 bhp (82.0kW) @ 2500 rpm.

Operators Control Station

Frame mounted, open air style control station with cab shell includes all crane functions, driving controls, and overhead safety glass. Other standard equipment include a durable weather resistant seat with seat belt, hourmeter, sight level bubble, and fire extinguisher. The dash panel includes engine oil pressure gauge, engine water temperature gauge, fuel gauge, transmission low oil and high temperature warning lights, low battery warning light, and brake system low pressure warning light. The LSI (load indicator) receiver is mounted to the top of the dash.

*Operators Control Station Enclosed

Includes the standard cab shell with the addition of front and rear glass and sliding glass on the right side. Hinged full door with sliding glass.

Front windshield wiper and heater and defroster is included.

Fuel Tank Capacity

40 gallon (151.4 L) all steel construction with steel side plate to guard against side impact.

Electrical System

One 12V maintenance free battery, 820CCA @ 0°. 63 amp alternator.

Drive

4 x 2 – Front axle drive with planetary hubs and limited slip differential.

Steer

YB5515: 2-wheel and 4-wheel (coordinated)

YB5518: 2-wheel, -4-wheel, and crab steer w/electric self alignment.

Transmission

YB5515: Clark synchromesh 4-speeds forward and reverse.

YB5518: Clark powershift 4-speeds forward and reverse. Stalk mounted shifter on left side of steering column.

Tires

385/65R 22.5 radial traction tread pneumatic.

Brakes

Hydraulic actuated internal wet-disc service brakes acting on all four wheels. A dash mounted toggle switch activates the dry disc parking brake on the transmission output yoke with a dash warning light.

Suspension

Front: Rigid mounted to frame.

Rear: Provides 1.5° oscillation for use on semi-rough terrain. Axle lock-out must be engaged (locked) whenever picking on rubber or traveling in the crab steer mode. A warning light indicates when the axle lock-outs are engaged.

*Optional 4° oscillation.

Lights

Recessed mounted, includes head, tail, rear work, stop, and turn signals.

Maximum Speed

YB5515: 14.5 mph (23.3km/h)

YB5518: 21.0 mph (33.8km/h)

Gradeability**

YB5515: 73%.....no load
41%.....20,000lb (9 072kg) load

YB5518: 68%.....no load
40%.....20,000lb (9 072kg) load

G.V.W.

YB5515: 26,300 lb (11 930kg) 3-section boom

26,750 lb (12 134kg) 4-section boom

YB5518: 30,000 lb (13 608kg)

Miscellaneous Standard Equipment

Two sheave, "Quick Reeve" style hookblock; YB5515: 15.0T (13.6mt); YB5518: 18.0T (16.3mt).

Back-up alarm

*Denotes Optional Equipment

**Theoretical

dimensions

YB5515

5

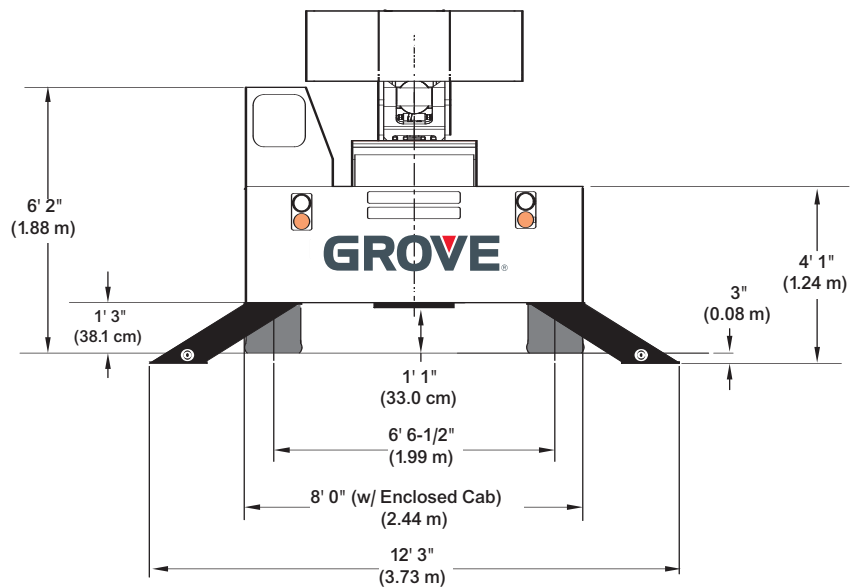
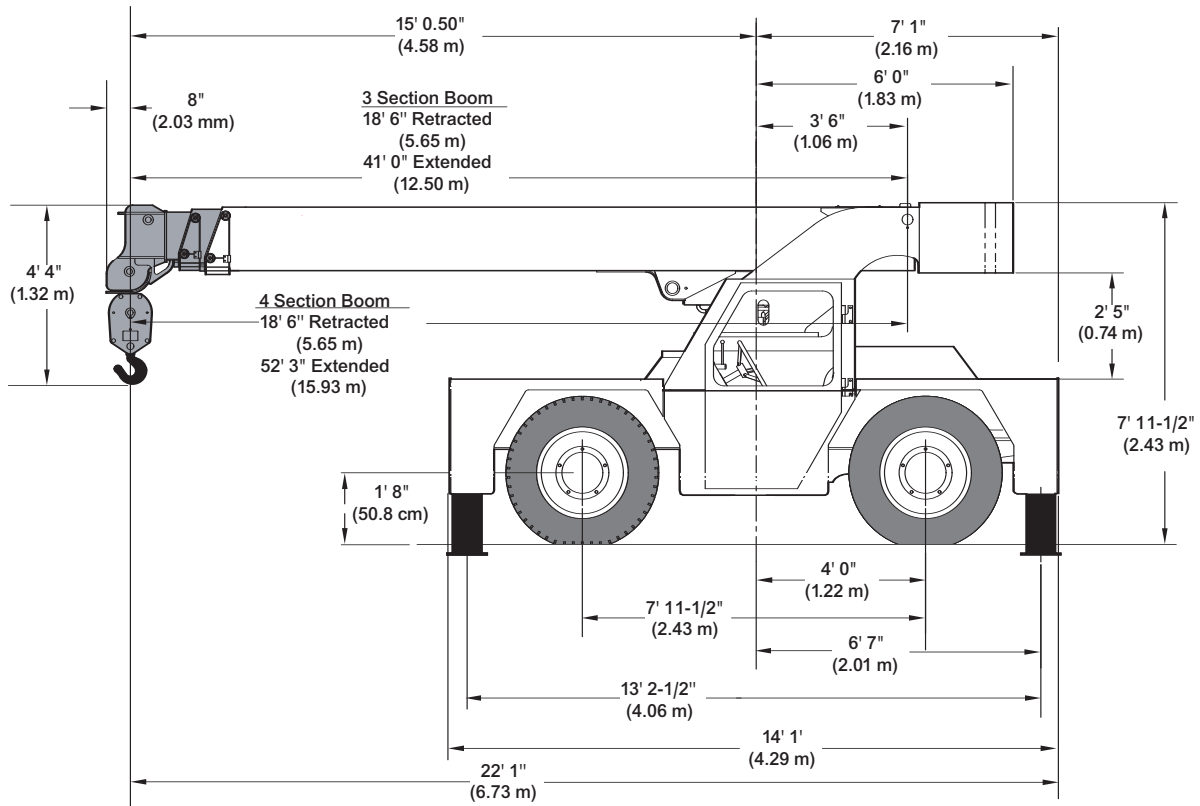

YB5500 Series

GROVE

Courtesy of Crane.Market

range diagram

3-SECTION BOOM

YB5515

6

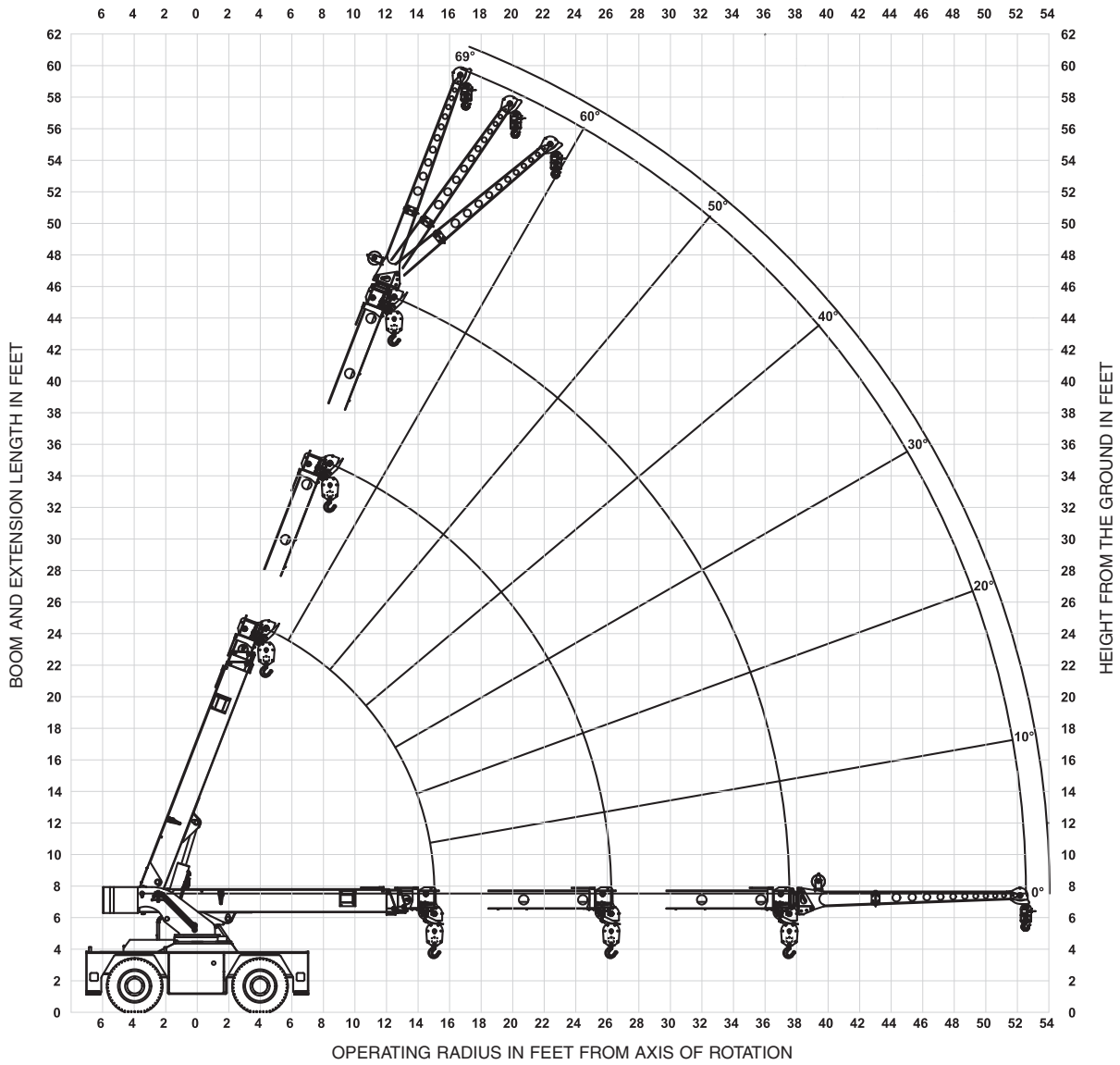

YB5500 Series

THIS CHART IS ONLY A GUIDE AND SHOULD NOT BE USED TO OPERATE THE CRANE. The individual crane's load chart, operating instructions and other instructional plates must be read and understood prior to operating the crane.

GROVE

Courtesy of Crane.Market

range diagram

YB5515

4-SECTION BOOM

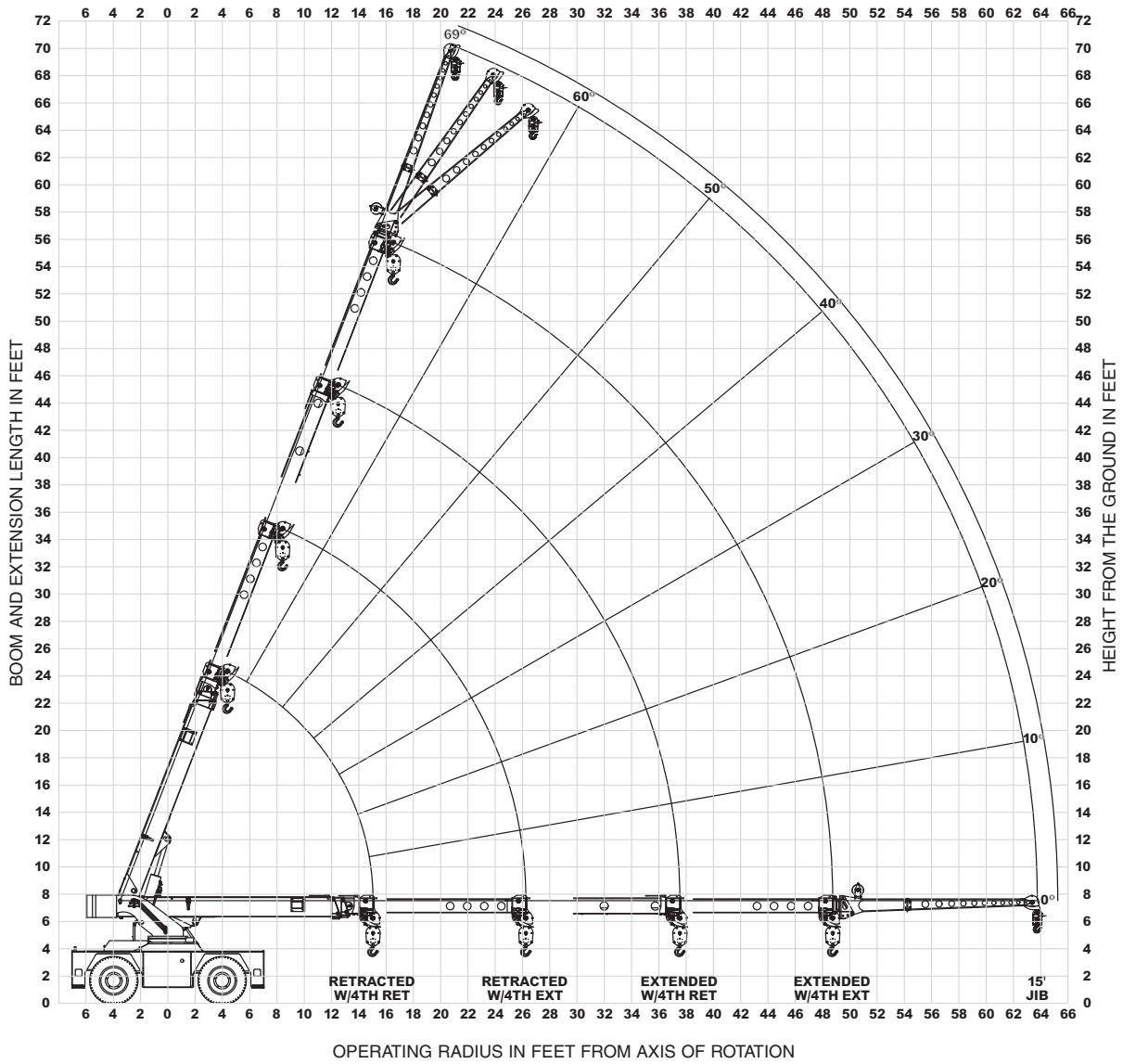

7

YB5500 Series

THIS CHART IS ONLY A GUIDE AND SHOULD NOT BE USED TO OPERATE THE CRANE. The individual crane's load chart, operating instructions and other instructional plates must be read and understood prior to operating the crane.

GROVE

Courtesy of Crane.Market

load chart

YB5515 w/3-section boom

8

	RADIUS (ft)	ON OUTRIGGERS (lbs)		ON RUBBER (lbs)	
		F/R	360°	F/R	360°
MAIN BOOM	6.0	30000	30000	17000	17000
	8.0	26200	26200	13500	14600
	10.0	22300	22300	10700	10880
	12.0	18600	18600	8710	8100
	14.0	14800	14800	7210	6000
	15.0	13000	13000	6600	5250
	16.0	12200	12200	6060	4760
	18.0	10800	10800	5120	3900
	20.0	9630	9180	4370	3190
	22.0	8640	7480	3710	2660
	24.0	7790	6210	3070	2200
	26.0	7040	5310	2620	1820
	28.0	6420	4740	2260	1530
	30.0	5700	4290	1990	1320
	32.0	5060	3920	1790	1160
	34.0	4510	3580	1610	1040
	36.0	4020	3260	1460	930
	37.5	3700	3060	1370	860
JIB	40.0	3480	2860	1270	800
	42.0	3310	2700	1190	740
	44.0	3130	2560	1120	690
	46.0	2960	2410	1040	640
	48.8	2710	2210	930	570
	52.5	2390	1940	790	480

MAIN BOOM ANGLE (deg)	JIB STRUCTURAL CAPACITIES (lbs)		
	0°	15°	30°
69	6000	3900	2800
65	5000	3500	2550
60	4300	3150	2350
55	3800	2850	2200
50	3400	2600	2100
45	3050	2400	2000
40	2800	2250	1950
35	2600	2150	1900
30	2400	2080	1850
25	2300	2050	-
20	2200	2000	-
15	2100	1950	-
10	2050	-	-
5	2020	-	-
0	2000	-	-

JIB CAPACITY IS LIMITED BY BOTH STRUCTURAL CAPACITY CHART AND MAIN CAPACITY CHART.

SHADED AREAS ARE GOVERNED BY STRUCTURAL STRENGTH, DO NOT RELY ON TIPPING.

OPERATION OF THIS EQUIPMENT IN EXCESS OF RATING CHARTS AND DISREGARD OF INSTRUCTIONS IS DANGEROUS AND VOIDS WARRANTY.

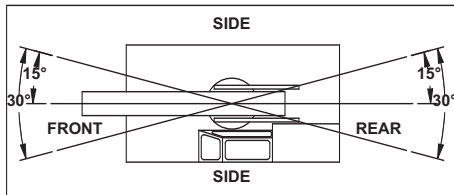

REDUCTION CHART		
	FROM MAIN BOOM RATINGS	FROM JIB RATINGS
MAIN BLOCK	210 lbs	N/A
HOOK & BALL	100 lbs	100 lbs
JIB, STOWED	0 lbs	N/A
JIB, DEPLOYED	700 lbs	0 lbs

RIGGING CHART	
1-PART 0-7500 lbs	4-PART 0-30000 lbs
WIRE ROPE: 1/2 inch diameter Min. breaking strength 26250 lbs.	

- The rated loads are the maximum lifting capacities as determined by operating radius only. Any combination of boom lengths and angles may be used to obtain operating radius. The operating radius is the horizontal distance from a projection of the axis of rotation to the supporting surface, before loading, to the center of vertical hoist line or tackle with load applied.
- The rated loads shown on outriggers do not exceed 85% of actual tipping. The rated loads shown on rubber do not exceed 75% of actual tipping. These ratings are based on freely suspended loads with the crane leveled, standing on a firm, uniform supporting surface. Practical working loads depend on supporting surface, operating radius and other factors affecting stability. Hazardous surroundings, climatic conditions, experience of operator and proper training must be taken into account by the operator.
- The weights of all load handling devices, such as hooks, hook blocks, slings, etc., except the hoist rope, shall be considered as part of the load. See reduction chart.
- Ratings on outriggers are with outriggers fully extended.
- Ratings on rubber depend on tire capacity, condition of tires and proper inflation pressure (120 psi). Loads on rubber may be transported at a maximum speed of 2.5 mph on a smooth, hard, level surface with the boom retracted to the shortest length possible and centered over the front.
- For operating radius not shown, use load rating of next larger radius.
- The maximum combined total boom and deck load is 16000 lbs. The maximum deck load only is 20000 lbs.
- Do not induce any external side loads to boom or jib.

THIS CHART IS ONLY A GUIDE AND SHOULD NOT BE USED TO OPERATE THE CRANE. The individual crane's load chart, operating instructions and other instructional plates must be read and understood prior to operating the crane.

YB5500 Series

load chart

YB5515 w/ 4-section boom

RADIUS (ft)	4TH RETRACTED				RADIUS (ft)	4TH EXTENDED			
	ON OUTRIGGERS (lbs)		ON RUBBER (lbs)			ON OUTRIGGERS (lbs)		ON RUBBER (lbs)	
	F/R	360°	F/R	360°		F/R	360°	F/R	360°
6.0	30000	30000	17000	17000	6.0	-	-	-	-
8.0	26200	26200	13500	14600	8.0	11000	11000	11000	11000
10.0	22300	22300	10700	11000	10.0	10700	10700	10700	10700
12.0	18600	18600	8710	7650	12.0	9250	9250	9250	9250
14.0	14800	14800	7210	5480	14.0	8290	8390	7760	7500
15.0	13000	13000	6600	4890	15.0	8200	8200	7150	6080
16.0	12200	12200	6060	4500	16.0	8110	8110	6610	5510
18.0	10800	10600	4950	3750	18.0	7950	7950	5680	4500
20.0	9630	8630	3980	3080	20.0	7820	7820	4730	3560
22.0	8640	7350	3230	2460	22.0	7710	7710	3980	3000
24.0	7790	6460	2720	1990	24.0	7630	7270	3410	2520
26.0	6800	5700	2360	1610	26.0	7100	6330	2940	2150
28.0	5820	5040	2100	1410	28.0	6590	5420	2550	1840
30.0	5020	4420	1880	1220	30.0	5710	4760	2190	1580
32.0	4400	3950	1650	1070	32.0	5180	4080	1880	1360
34.0	3930	3570	1460	920	34.0	4680	3570	1600	1160
36.0	3510	3190	1280	770	36.0	4250	3190	1370	990
37.5	3210	2890	1180	680	37.5	3830	2970	1240	880
40.0	2950	2600	1070	610	40.0	3400	2700	1070	740
42.0	2760	2430	970	550	42.0	3150	2490	960	630
44.0	2590	2250	890	500	44.0	2890	2300	870	540
46.0	2430	2090	800	450	46.0	2630	2130	790	470
48.8	2240	1850	680	380	48.8	2320	1930	710	370
52.5	2030	1480	500	290	52.5	2070	1710	590	280
58.0	-	-	-	-	58.0	1720	1380	420	170
63.8	-	-	-	-	63.8	1330	1020	230	60

MAIN BOOM ANGLE (deg)	JIB STRUCTURAL CAPACITIES (lbs)					
	4TH RETRACTED			4TH EXTENDED		
	0°	15°	30°	0°	15°	30°
69	6000	3900	2800	5180	3900	2800
65	5000	3500	2550	4970	3500	2550
60	4300	3150	2350	4300	3150	2350
55	3800	2850	2200	3800	2850	2200
50	3400	2600	2100	3400	2600	2100
45	3050	2400	2000	3050	2400	2000
40	2800	2250	1950	2800	2250	1950
35	2600	2150	1900	2600	2150	1900
30	2400	2080	1850	2400	2080	1850
25	2300	2050	-	2300	2050	-
20	2200	2000	-	2200	2000	-
15	2100	1950	-	2100	1950	-
10	2050	-	-	2050	-	-
5	2020	-	-	2020	-	-
0	2000	-	-	2000	-	-

JIB CAPACITY IS LIMITED BY BOTH STRUCTURAL CAPACITY CHART AND MAIN CAPACITY CHART.

SHADED AREAS ARE GOVERNED BY STRUCTURAL STRENGTH, DO NOT RELY ON TIPPING.

OPERATION OF THIS EQUIPMENT IN EXCESS OF RATING CHARTS AND DISREGARD OF INSTRUCTIONS IS DANGEROUS AND VOIDS WARRANTY.

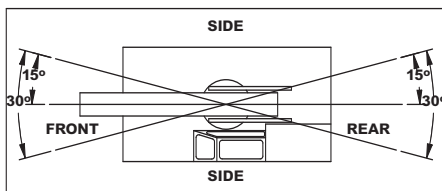

REDUCTION CHART		
	FROM MAIN BOOM RATINGS	FROM JIB RATINGS
MAIN BLOCK	210 lbs	N/A
HOOK & BALL	100 lbs	100 lbs
JIB, STOWED	0 lbs	N/A
JIB, DEPLOYED	700 lbs	0 lbs

RIGGING CHART	
1-PART 0-7500 lbs	4-PART 0-30000 lbs
WIRE ROPE: 1/2 inch diameter Min. breaking strength 26250 lbs.	

- The rated loads are the maximum lifting capacities as determined by operating radius only. Any combination of boom lengths and angles may be used to obtain operating radius. The operating radius is the horizontal distance from a projection of the axis of rotation to the supporting surface, before loading, to the center of vertical hoist line or tackle with load applied.
- The rated loads shown on outriggers do not exceed 85% of actual tipping. The rated loads shown on rubber do not exceed 75% of actual tipping. These ratings are based on freely suspended loads with the crane leveled, standing on a firm, uniform supporting surface. Practical working loads depend on supporting surface, operating radius and other factors affecting stability. Hazardous surroundings, climatic conditions, experience of operator and proper training must be taken into account by the operator.
- The weights of all load handling devices, such as hooks, hook blocks, slings, etc., except the hoist rope, shall be considered as part of the load. See reduction chart.
- Ratings on outriggers are with outriggers fully extended.
- Ratings on rubber depend on tire capacity, condition of tires and proper inflation pressure (120 psi). Loads on rubber may be transported at a maximum speed of 2.5 mph on a smooth, hard, level surface with the boom retracted to the shortest length possible and centered over the front.
- For operating radius not shown, use load rating of next larger radius.
- The maximum combined total boom and deck load is 16000 lbs. The maximum deck load only is 20000 lbs.
- Do not induce any external side loads to boom or jib.

THIS CHART IS ONLY A GUIDE AND SHOULD NOT BE USED TO OPERATE THE CRANE. The individual crane's load chart, operating instructions and other instructional plates must be read and understood prior to operating the crane.

dimensions

YB5518

10

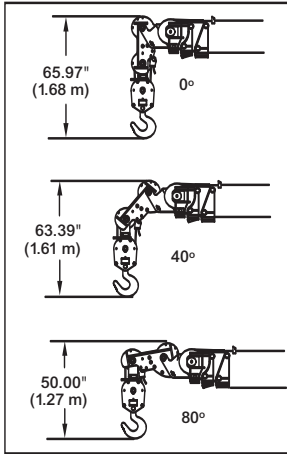

Dimensions are with the boom horizontal and the anti-two block bottomed.

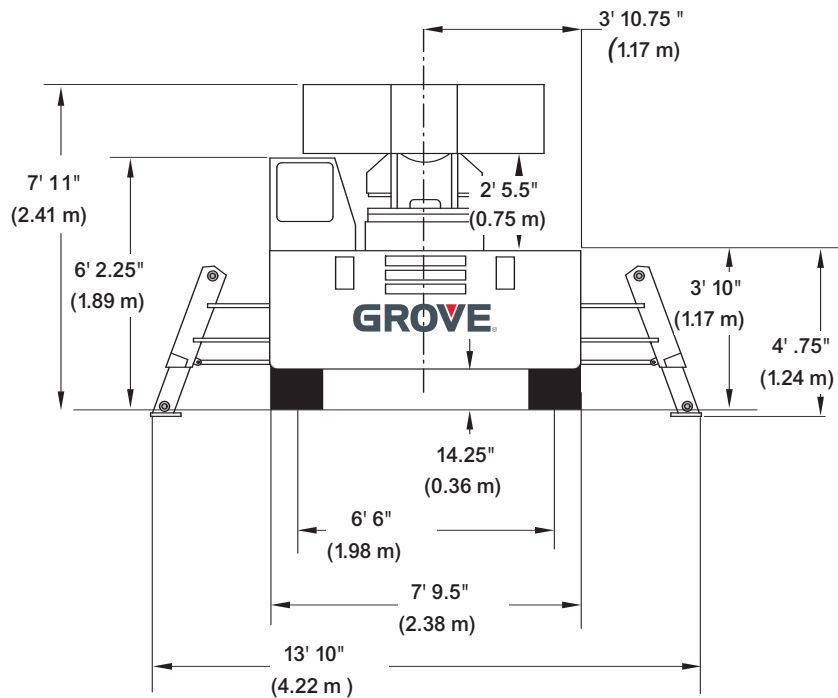
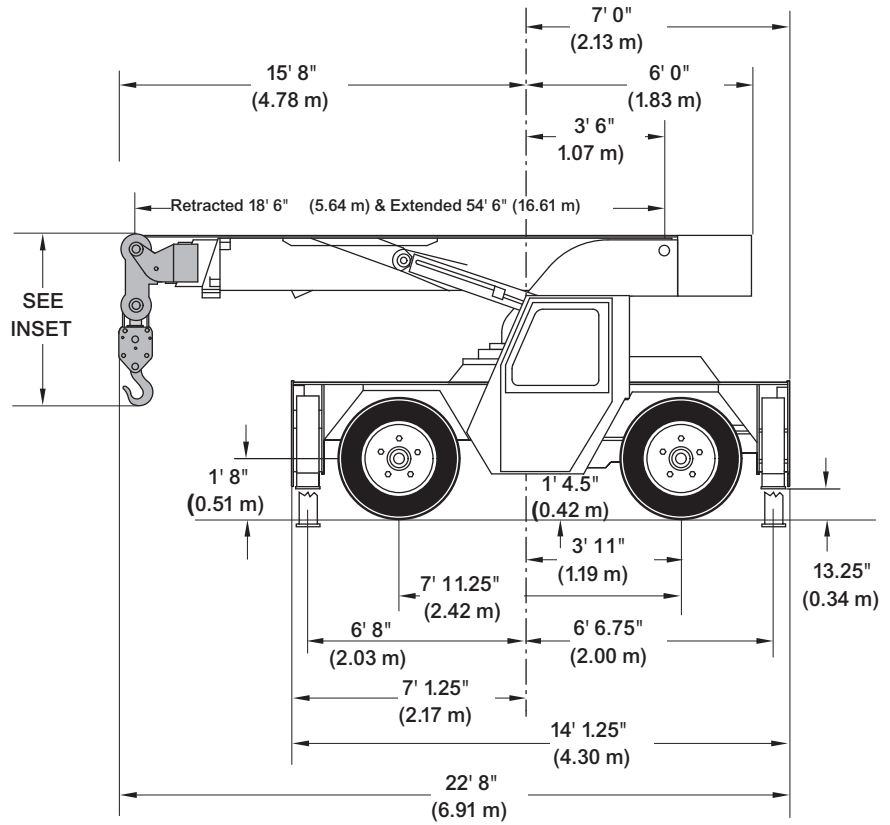

YB5500 Series

THIS CHART IS ONLY A GUIDE AND SHOULD NOT BE USED TO OPERATE THE CRANE. The individual crane's load chart, operating instructions and other instructional plates must be read and understood prior to operating the crane.

range diagram

YB5518

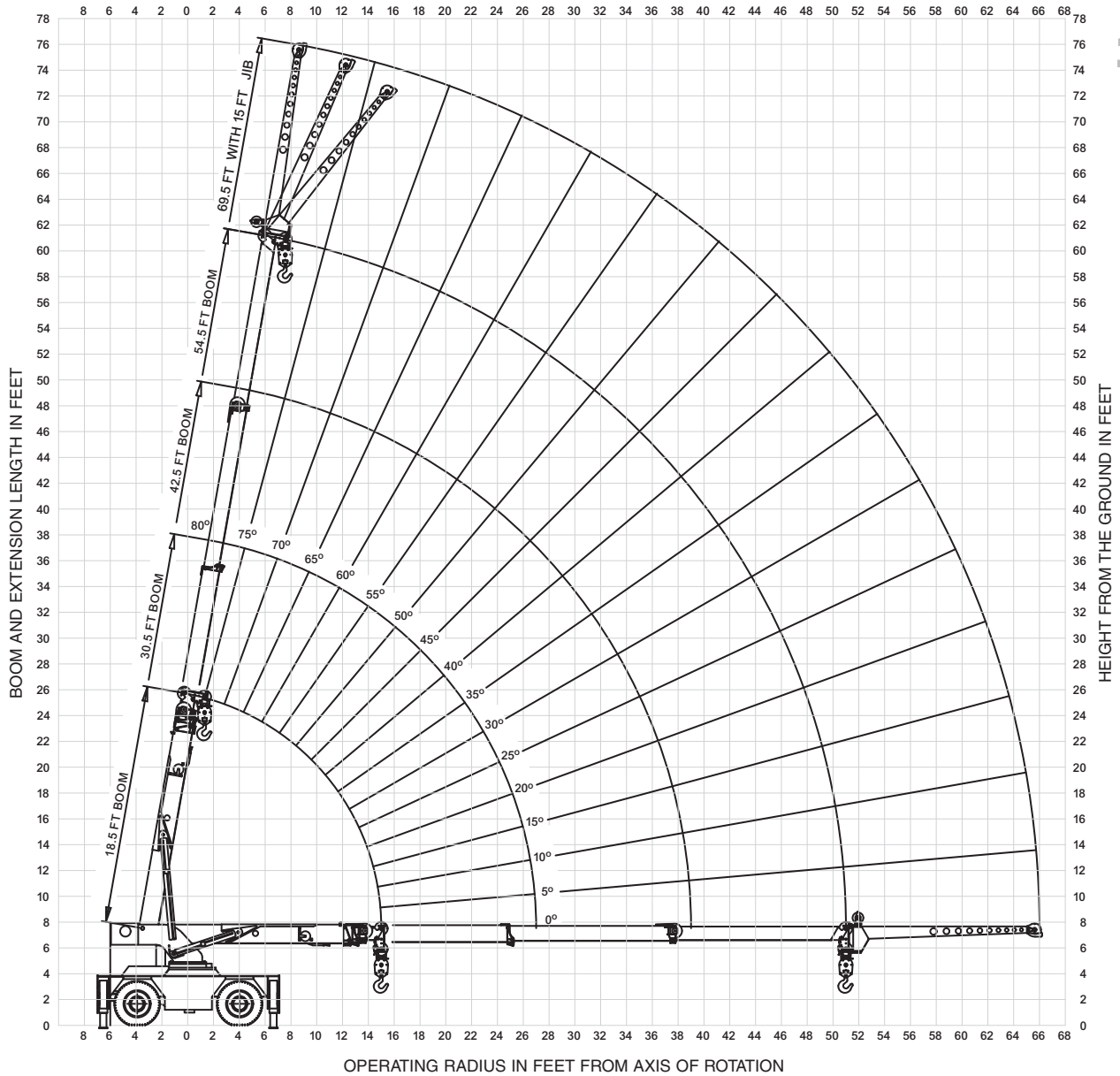

11

YB5500 Series

THIS CHART IS ONLY A GUIDE AND SHOULD NOT BE USED TO OPERATE THE CRANE. The individual crane's load chart, operating instructions and other instructional plates must be read and understood prior to operating the crane.

GROVE

Courtesy of Crane.Market

load chart

YB5518

12

MAIN BOOM LOAD RATINGS ON OUTRIGGERS Extended and Down 360° or Retracted and Down Front/Rear								
Radius (ft)	18.5 ft BOOM		30.5 ft BOOM		42.5 ft BOOM		54.5 ft BOOM	
	Boom Angle (deg)	Rated Load (lbs)	Boom Angle (deg)	Rated Load (lbs)	Boom Angle (deg)	Rated Load (lbs)	Boom Angle (deg)	Rated Load (lbs)
6	64	36000	75	24500	79	23700	-	-
8	57	31500	71	24500	77	23000	80	17400
10	49	24000	67	24000	74	21500	77	15800
12	39	19500	63	20000	71	19700	75	14000
14	25	16200	58	16800	68	17000	73	12600
15.0	0	15000	56	15500	66	15800	72	12000
16	-	-	53	14400	65	14600	71	11400
18	-	-	48	12500	62	12700	69	10500
20	-	-	43	11000	59	11200	66	9600
22	-	-	37	9800	55	10000	64	8900
24	-	-	29	8700	52	9000	61	8300
26	-	-	18	7800	48	8100	59	7700
27.0	-	-	0	7400	46	7700	58	7500
28	-	-	-	-	44	7300	56	7200
30	-	-	-	-	40	6500	54	6700
32	-	-	-	-	36	5700	51	6000
34	-	-	-	-	30	5100	48	5400
36	-	-	-	-	24	4500	45	4800
38	-	-	-	-	15	4000	42	4300
39.0	-	-	-	-	0	3900	41	4000
40	-	-	-	-	-	-	39	3800
42	-	-	-	-	-	-	35	3400
44	-	-	-	-	-	-	31	3100
46	-	-	-	-	-	-	27	2900
48	-	-	-	-	-	-	21	2700
51.0	-	-	-	-	-	-	0	2400

MAIN BOOM ON RUBBER		
Radius (ft)	Any Boom Length	
	Front Rating (lbs)	360° Rating (lbs)
6	16000	10900
8	13000	8700
10	11000	7400
12	9100	6400
14	7800	5600
15.0	7100	5300
16	6500	4900
18	5600	4200
20	4800	3500
22	4200	3000
24	3600	2500
26	3150	2200
27.0	2950	2050
28	2800	1900
30	2450	1650
32	2100	1400
34	1900	1200
36	1750	1000
38	1525	850
39.0	1450	775
40	1350	725
42	1150	625
44	1050	525
46	950	425
48	850	300
51.0	700	200

RATING REDUCTIONS FOR LOAD HANDLING DEVICES INSTALLED (lbs)		
	FROM MAIN BOOM	FROM JIB
MAIN BLOCK	230	NOT APPLICABLE
HOOK & BALL	100	100
JIB STOWED	NO REDUCTION	NOT APPLICABLE
JIB DEPLOYED	700	NO REDUCTION

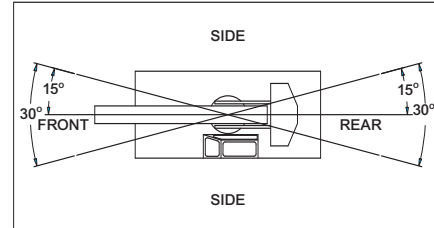

SHADED AREAS ARE GOVERNED BY STRUCTURAL STRENGTH, DO NOT RELY ON TIPPING.

OPERATION OF THIS EQUIPMENT IN EXCESS OF RATING CHARTS AND DISREGARD OF INSTRUCTIONS IS DANGEROUS AND VOIDS WARRANTY.

MAIN BOOM LOAD RATINGS ON OUTRIGGERS Retracted and Down 360°								
Radius (ft)	18.5 ft BOOM		30.5 ft BOOM		42.5 ft BOOM		54.5 ft BOOM	
	Boom Angle (deg)	Rated Load (lbs)	Boom Angle (deg)	Rated Load (lbs)	Boom Angle (deg)	Rated Load (lbs)	Boom Angle (deg)	Rated Load (lbs)
6	64	36000	75	24500	79	23700	-	-
8	57	29000	71	24500	77	23000	80	17400
10	49	16000	67	22000	74	20000	77	15800
12	39	11400	63	12900	71	12800	75	13000
14	25	8900	58	9900	68	10200	73	10600
15.0	0	8000	56	8900	66	9300	72	9500
16	-	-	53	8100	65	8500	71	8500
18	-	-	48	6800	62	7200	69	7200
20	-	-	43	5900	59	6200	66	6100
22	-	-	37	5000	55	5200	64	5300
24	-	-	29	4100	52	4500	61	4500
26	-	-	18	3600	48	3800	59	3900
27.0	-	-	0	3400	46	3600	58	3600
28	-	-	-	-	44	3300	56	3300
30	-	-	-	-	40	2900	54	2800
32	-	-	-	-	36	2500	51	2500
34	-	-	-	-	30	2200	48	2200
36	-	-	-	-	24	2000	45	2000
38	-	-	-	-	15	1800	42	1800
39.0	-	-	-	-	0	1700	41	1700
40	-	-	-	-	-	-	39	1600
42	-	-	-	-	-	-	35	1400
44	-	-	-	-	-	-	31	1300
46	-	-	-	-	-	-	27	1100
48	-	-	-	-	-	-	21	900
51.0	-	-	-	-	-	-	0	700

- The rated loads are the maximum lift capacities as determined by operating radius, boom length and boom angle. The operating radius is the horizontal distance from a projection of the axis of rotation to the supporting surface, before loading, to the center of vertical hoist line or tackle with load applied.
- The rated loads shown on outriggers do not exceed 85% of actual tipping. The rated loads shown on rubber do not exceed 75% of actual tipping. These ratings are based on freely suspended loads with the crane leveled, standing on a firm, uniform supporting surface. Practical working loads depend on supporting surface, operating radius and other factors affecting stability. Hazardous surroundings, climatic conditions, experience of personnel and proper handling must all be taken into account by the operator.
- The weights of all load handling devices, such as hooks, hook blocks, slings, etc., except the hoist rope, shall be considered as part of the load. See above.
- Ratings on outriggers are for either outriggers fully extended and down or fully retracted and down. Ratings for outriggers fully retracted and down will apply for any intermediate outrigger setting.
- Ratings on rubber depend on tire capacity, condition of tires and proper inflation pressure (120 psi). Loads on rubber may be transported at a maximum speed of 2.5 mph on a smooth hard level surface with boom retracted to the shortest length possible and centered over front. Do not use jib with crane on rubber.
- For operating radius not shown, use load rating of next larger radius.
- The maximum combined total boom and deck load is 16,000 lbs. The maximum deck load only is 20,000 lbs.
- Do not induce any external side loads to boom or jib.

MAXIMUM PERMISSIBLE SINGLE LINE PULL = 9000 lbs

WIRE ROPE: 1/2 inch dia. 10 x 19 EIPS IWRC BRIGHT
Min. req'd breaking strength = 31,500 lbs

15 FT JIB CAPACITIES ON EXTENDED OUTRIGGERS					
Main Boom Angle (deg)	Jib Offset Angle				
	0 deg		15 deg		Any Boom Length
	To 42.5 ft Main Boom	To 54.5 ft Main Boom	To 42.5 ft Main Boom	To 54.5 ft Main Boom	
80	-	-	5000	5000	3500
75	7500	-	4400	4400	3100
70	6100	-	3900	3900	2800
65	5000	4600	3500	3500	2550
60	4300	3800	3150	3150	2350
55	3800	3300	2850	2850	2200
50	3400	2900	2600	2600	2100
45	3050	2600	2400	2400	2000
40	2800	2400	2250	2250	1950
35	2600	2150	2150	2050	1900
30	2400	1930	2080	1850	1830
25	2300	1750	2050	1720	-
20	2200	1600	2000	1590	-
15	2100	1500	1950	1520	-
10	2050	1460	-	-	-
5	2020	1450	-	-	-
0	2000	1440	-	-	-

THIS CHART IS ONLY A GUIDE AND SHOULD NOT BE USED TO OPERATE THE CRANE. The individual crane's load chart, operating instructions and other instructional plates must be read and understood prior to operating the crane.

YB5500 Series

range diagram

YB5515 (w/3-section boom)

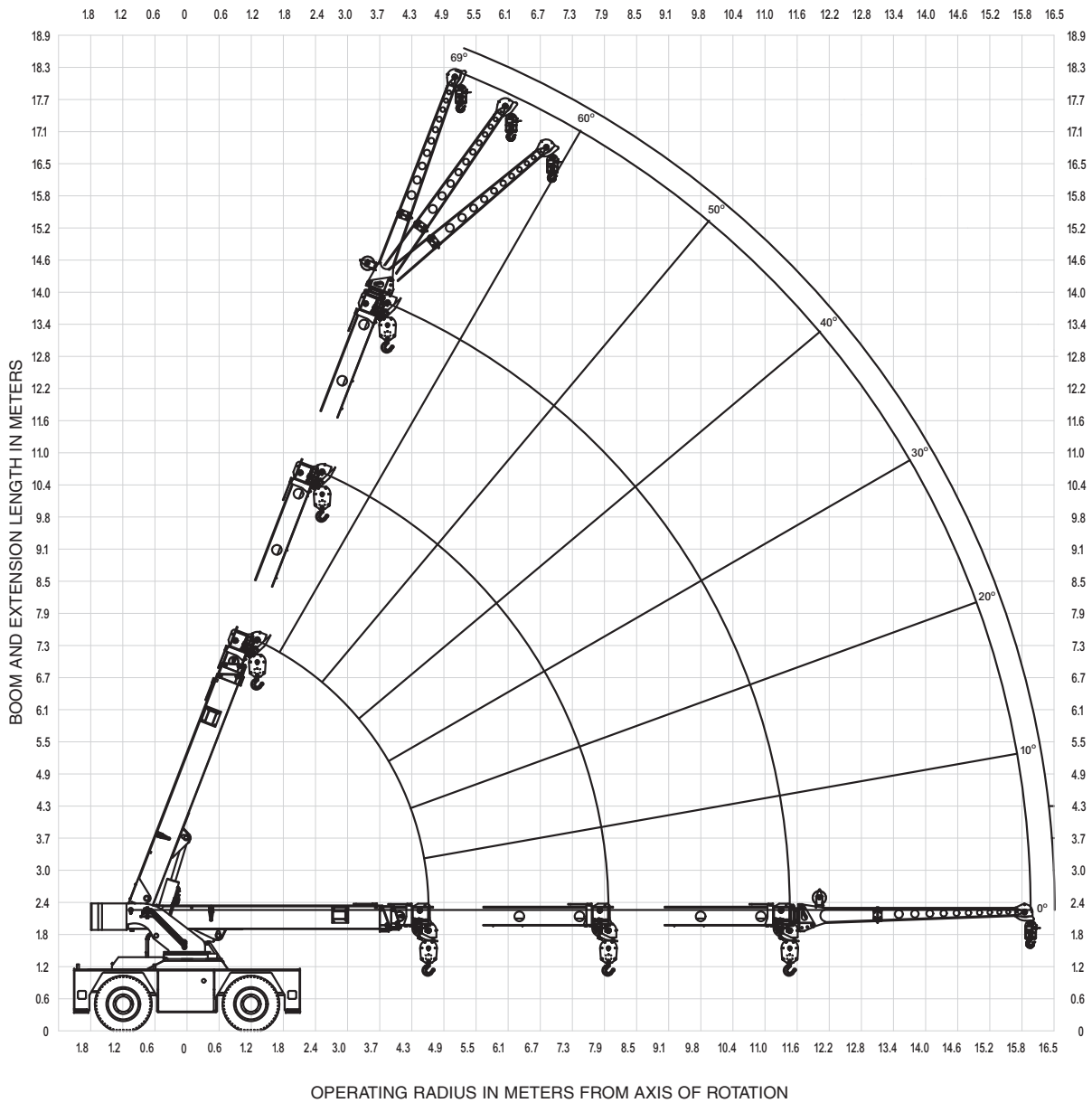

13

YB5500 Series

THIS CHART IS ONLY A GUIDE AND SHOULD NOT BE USED TO OPERATE THE CRANE. The individual crane's load chart, operating instructions and other instructional plates must be read and understood prior to operating the crane.

GROVE

Courtesy of Crane.Market

range diagram

YB5515 (w/4-section boom)

14

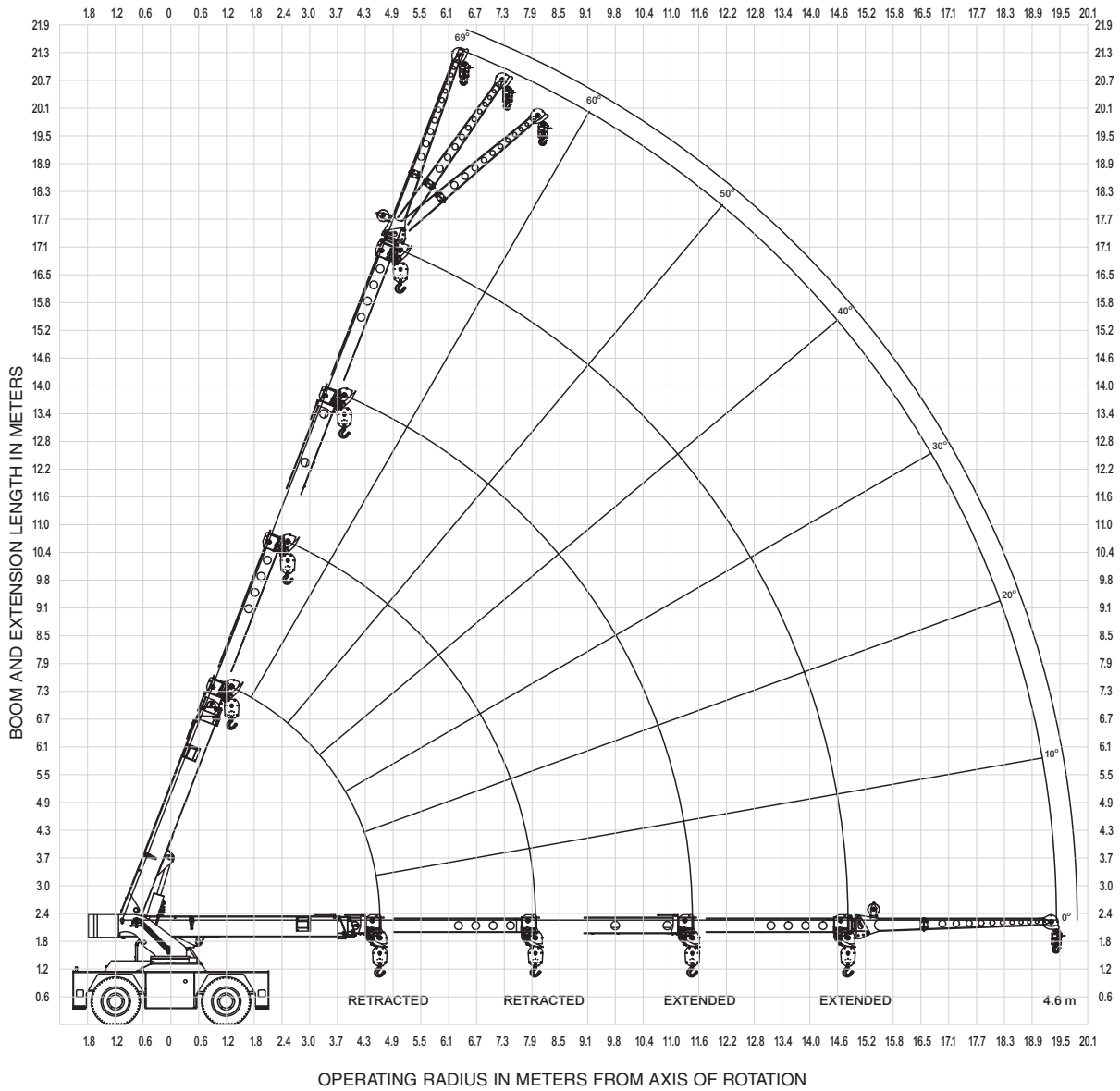

YB5500 Series

THIS CHART IS ONLY A GUIDE AND SHOULD NOT BE USED TO OPERATE THE CRANE. The individual crane's load chart, operating instructions and other instructional plates must be read and understood prior to operating the crane.

DIN/ISO load chart

YB5515 (w/3-section boom)

15

	RADIUS (m)	ON OUTRIGGERS (kg)		ON RUBBER (kg)	
		F/R	360°	F/R	360°
MAIN BOOM	1.8	13610	13610	7710	7710
	2.4	11880	11880	6120	6620
	3.0	10120	10120	4850	4860
	3.7	8440	8440	3950	3600
	4.3	6710	6710	3270	2650
	4.6	5900	5900	2990	2310
	4.9	5540	5530	2750	2090
	5.5	4900	4750	2320	1700
	6.1	4370	3840	1940	1370
	6.7	3920	3120	1610	1130
	7.3	3460	2570	1320	920
	7.9	3010	2190	1110	750
	8.5	2660	1950	950	620
	9.1	2350	1750	830	530
	9.8	2080	1600	740	450
10.4	1850	1450	660	400	
11.0	1640	1310	590	350	
11.4	1500	1230	550	320	
JIB	12.2	1410	1140	500	290
	12.8	1330	1080	470	260
	13.4	1260	1010	430	240
	14.0	1190	950	400	220
	14.9	1080	870	350	190
	16.0	940	750	280	140

MAIN BOOM ANGLE (deg)	JIB STRUCTURAL CAPACITIES (kg)		
	0°	15°	30°
69	2720	1770	1270
65	2270	1590	1160
60	1950	1430	1070
55	1720	1290	1000
50	1540	1180	950
45	1380	1090	910
40	1270	1020	880
35	1180	980	860
30	1090	940	840
25	1040	930	-
20	1000	910	-
15	950	880	-
10	930	-	-
5	920	-	-
0	910	-	-

JIB CAPACITY IS LIMITED BY BOTH STRUCTURAL CAPACITY CHART AND MAIN CAPACITY CHART.

SHADED AREAS ARE GOVERNED BY STRUCTURAL STRENGTH, DO NOT RELY ON TIPPING.

OPERATION OF THIS EQUIPMENT IN EXCESS OF RATING CHARTS AND DISREGARD OF INSTRUCTIONS IS DANGEROUS AND VOIDS WARRANTY.

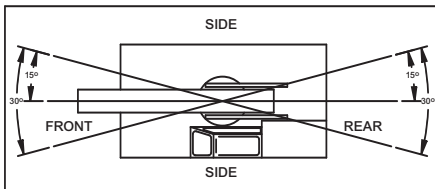

REDUCTION CHART		
	FROM MAIN BOOM RATINGS	FROM JIB RATINGS
MAIN BLOCK	100 kg	N/A
HOOK & BALL	50 kg	50 kg
JIB, STOWED	0 kg	N/A
JIB, DEPLOYED	320 kg	0 kg

RIGGING CHART	
<p>1-PART 0-3400 kg</p>	<p>4-PART 0-13610 kg</p>
<p>WIRE ROPE: 13 mm diameter Min. breaking strength 128.4 kN.</p>	

- The rated loads are the maximum lifting capacities as determined by operating radius only. Any combination of boom lengths and angles may be used to obtain operating radius. The operating radius is the horizontal distance from a projection of the axis of rotation to the supporting surface, before loading, to the center of vertical hoist line or tackle with load applied.
- The rated loads shown on outriggers do not exceed 80% of actual tipping. The rated loads shown on rubber do not exceed 75% of actual tipping. These ratings are based on freely suspended loads with the crane leveled, standing on a firm, uniform supporting surface. Practical working loads depend on supporting surface, operating radius and other factors affecting stability. Hazardous surroundings, climatic conditions, experience of operator and proper training must be taken into account by the operator.
- The weights of all load handling devices, such as hooks, hook blocks, slings, etc., except the hoist rope, shall be considered as part of the load. See reduction chart.
- Ratings on outriggers are with outriggers fully extended.
- Ratings on rubber depend on tire capacity, condition of tires and proper inflation pressure (8.3 bar). Loads on rubber may be transported at a maximum speed of 1.4 km/h on a smooth, hard, level surface with the boom retracted to the shortest length possible and centered over the front.
- For operating radius not shown, use load rating of next larger radius.
- The maximum combined total boom and deck load is 7 260 kgs. The maximum deck load only is 9 070 kgs.
- Do not induce any external side loads to boom or jib.

THIS CHART IS ONLY A GUIDE AND SHOULD NOT BE USED TO OPERATE THE CRANE. The individual crane's load chart, operating instructions and other instructional plates must be read and understood prior to operating the crane.

YB5500 Series

DIN/ISO load chart

YB5515 (w/4-section boom)

16

RADIUS (m)	4TH RETRACTED				RADIUS (m)	4TH EXTENDED				MAIN BOOM ANGLE (deg)	JIB STRUCTURAL CAPACITIES (kg)					
	ON OUTRIGGERS (kg)		ON RUBBER (kg)			ON OUTRIGGERS (kg)		ON RUBBER (kg)			4TH RETRACTED			4TH EXTENDED		
	F/R	360°	F/R	360°		F/R	360°	F/R	360°		0°	15°	30°	0°	15°	30°
1.8	13610	13610	7710	7710	1.8	-	-	-	-	69	2720	1770	1270	2350	1770	1270
2.4	11880	11880	6120	6120	2.4	5030	5030	5030	5030	65	2270	1590	1160	2250	1590	1160
3.0	10120	10120	4860	4890	3.0	4850	4850	4850	4850	60	1950	1430	1070	1950	1430	1070
3.7	8440	8440	3950	3390	3.7	4200	4200	4200	4200	55	1720	1290	1000	1720	1290	1000
4.3	6710	6710	3270	2400	4.3	3760	3760	3520	3320	50	1540	1180	950	1540	1180	950
4.6	5900	5900	2990	2140	4.6	3720	3720	3240	2670	45	1380	1090	910	1380	1090	910
4.9	5540	5540	2670	1960	4.9	3680	3680	3000	2420	40	1270	1020	880	1270	1020	880
5.5	4900	4450	2160	1620	5.5	3610	3610	2530	1960	35	1180	980	860	1180	980	860
6.1	4370	3600	1720	1310	6.1	3550	3550	2060	1530	30	1090	940	840	1090	940	840
6.7	3920	3050	1380	1030	6.7	3500	3500	1720	1280	25	1040	930	-	1040	930	-
7.3	3320	2670	1150	820	7.3	3460	3020	1470	1060	20	1000	910	-	1000	910	-
7.9	2820	2340	990	650	7.9	3180	2620	1250	890	15	950	880	-	950	880	-
8.5	2400	2060	870	560	8.5	2730	2230	1080	750	10	930	-	-	930	-	-
9.1	2050	1800	770	470	9.1	2350	1950	910	630	5	920	-	-	920	-	-
9.8	1790	1600	670	400	9.8	2120	1660	770	530	0	910	-	-	910	-	-
10.4	1590	1440	580	340	10.4	1910	1440	640	450							
11.0	1410	1270	500	270	11.0	1690	1270	540	370							
11.4	1290	1150	450	230	11.4	1550	1180	480	320							
12.2	1170	1020	400	190	12.2	1360	1070	400	250							
12.8	1090	950	360	170	12.8	1260	970	350	200							
13.4	1020	880	320	150	13.4	1150	890	310	160							
14.0	950	810	280	120	14.0	1040	820	280	130							
14.9	870	700	230	90	14.9	900	740	240	90							
16.0	780	550	150	50	16.0	800	640	190	50							
17.7	-	-	-	-	17.7	650	500	110	0							
19.4	-	-	-	-	19.4	480	350	20	0							

JIB CAPACITY IS LIMITED BY BOTH STRUCTURAL CAPACITY CHART AND MAIN CAPACITY CHART.

SHADED AREAS ARE GOVERNED BY STRUCTURAL STRENGTH, DO NOT RELY ON TIPPING.

OPERATION OF THIS EQUIPMENT IN EXCESS OF RATING CHARTS AND DISREGARD OF INSTRUCTIONS IS DANGEROUS AND VOIDS WARRANTY.

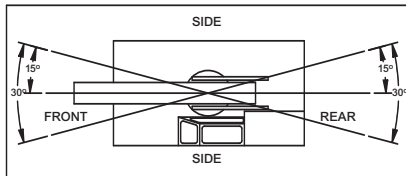

REDUCTION CHART		
	FROM MAIN BOOM RATINGS	FROM JIB RATINGS
MAIN BLOCK	100 kg	N/A
HOOK & BALL	50 kg	50 kg
JIB, STOWED	0 kg	N/A
JIB, DEPLOYED	320 kg	0 kg

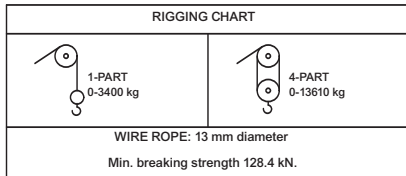

- The rated loads are the maximum lifting capacities as determined by operating radius only. Any combination of boom lengths and angles may be used to obtain operating radius. The operating radius is the horizontal distance from a projection of the axis of rotation to the supporting surface, before loading, to the center of vertical hoist line or tackle with load applied.
- The rated loads shown on outriggers do not exceed 80% of actual tipping. The rated loads shown on rubber do not exceed 75% of actual tipping. These ratings are based on freely suspended loads with the crane leveled, standing on a firm, uniform supporting surface. Practical working loads depend on supporting surface, operating radius and other factors affecting stability. Hazardous surroundings, climatic conditions, experience of operator and proper training must be taken into account by the operator.
- The weights of all load handling devices, such as hooks, hook blocks, slings, etc., except the hoist rope, shall be considered as part of the load. See reduction chart.
- Ratings on outriggers are with outriggers fully extended.
- Ratings on rubber depend on tire capacity, condition of tires and proper inflation pressure (8.3 bar). Loads on rubber may be transported at a maximum speed of 1.4 km/h on a smooth, hard, level surface with the boom retracted to the shortest length possible and centered over the front.
- For operating radius not shown, use load rating of next larger radius.
- The maximum combined total boom and deck load is 7 260 kgs. The maximum deck load only is 9 070 kgs.
- Do not induce any external side loads to boom or jib.

THIS CHART IS ONLY A GUIDE AND SHOULD NOT BE USED TO OPERATE THE CRANE. The individual crane's load chart, operating instructions and other instructional plates must be read and understood prior to operating the crane.

YB5500 Series

range diagram

YB5518

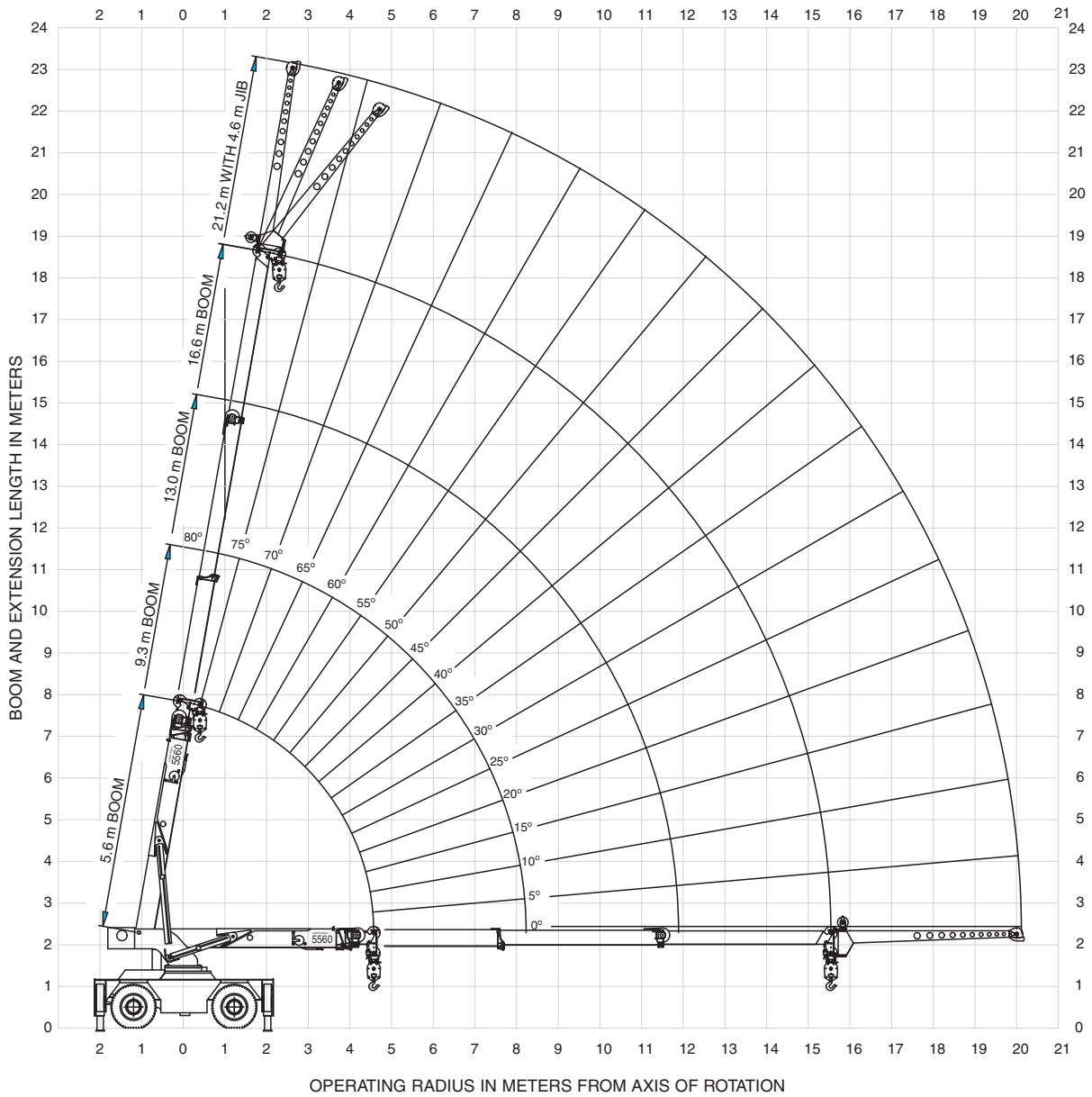

17

YB5500 Series

THIS CHART IS ONLY A GUIDE AND SHOULD NOT BE USED TO OPERATE THE CRANE. The individual crane's load chart, operating instructions and other instructional plates must be read and understood prior to operating the crane.

DIN/ISO load chart

18

YB5518

MAIN BOOM LOAD RATINGS ON OUTRIGGERS Extended and Down 360° or Retracted and Down Front/Rear								
Radius (m)	5.6 m BOOM		9.3 m BOOM		13.0 m BOOM		16.6 m BOOM	
	Boom Angle (deg)	Rated Load (kgs)	Boom Angle (deg)	Rated Load (kgs)	Boom Angle (deg)	Rated Load (kgs)	Boom Angle (deg)	Rated Load (kgs)
1.8	64	16330	75	10560	79	8230	-	-
2.4	57	14290	71	10430	76	8000	80	5860
3.0	48	10900	67	10000	74	7110	77	5800
3.7	38	8850	63	8880	71	6280	75	5530
4.3	25	7120	58	7260	68	5610	73	4920
4.6	0	6390	56	6640	66	5330	72	4660
4.9	-	-	53	6100	65	5070	71	4420
5.5	-	-	48	5220	62	4620	68	4020
6.1	-	-	43	4530	59	4240	66	3670
6.7	-	-	36	3980	55	3920	64	3380
7.3	-	-	29	3530	52	3570	61	3130
7.9	-	-	18	3160	48	3260	59	2910
8.2	-	-	0	3040	46	3100	58	2820
8.5	-	-	-	-	44	2960	56	2750
9.1	-	-	-	-	40	2625	54	2580
9.8	-	-	-	-	36	2335	51	2390
10.4	-	-	-	-	30	2050	48	2170
11.0	-	-	-	-	24	1810	45	1930
11.6	-	-	-	-	15	1630	42	1725
11.9	-	-	-	-	0	1550	40	1630
12.2	-	-	-	-	-	-	39	1540
12.8	-	-	-	-	-	-	35	1390
13.4	-	-	-	-	-	-	31	1270
14.0	-	-	-	-	-	-	26	1150
14.6	-	-	-	-	-	-	21	1045
15.5	-	-	-	-	-	-	0	930

MAIN BOOM ON RUBBER		
Radius (m)	Any Boom Length	
	Front Rating (kgs)	360° Rating (kgs)
1.8	7260	4950
2.4	5680	3950
3.0	4500	3360
3.7	3620	2880
4.3	3040	2390
4.9	2570	2000
5.5	2190	1690
6.1	1890	1430
6.7	1640	1210
7.3	1420	1030
7.9	1220	870
8.5	1090	740
9.1	950	630
9.8	840	525
10.4	720	430
11.0	610	340
11.6	520	270
12.2	470	215
12.8	400	165
13.4	340	120
14.0	280	80
14.6	230	45
15.5	150	0

RATING REDUCTIONS FOR LOAD HANDLING DEVICES INSTALLED (kgs)		
	FROM MAIN BOOM	FROM JIB
MAIN BLOCK	95	NOT APPLICABLE
HOOK & BALL	43	43
JIB STOWED	NO REDUCTION	NOT APPLICABLE
JIB DEPLOYED	318	NO REDUCTION

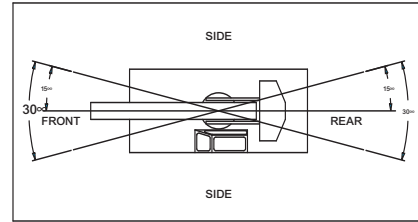

SHADED AREAS ARE GOVERNED BY STRUCTURAL STRENGTH, DO NOT RELY ON TIPPING.

OPERATION OF THIS EQUIPMENT IN EXCESS OF RATING CHARTS AND DISREGARD OF INSTRUCTIONS IS DANGEROUS AND VOIDS WARRANTY.

Note: For 360° rating on rubber, rear axle locks must be in place.

MAIN BOOM LOAD RATINGS ON OUTRIGGERS Retracted and Down 360°								
Radius (m)	5.6 m BOOM		9.3 m BOOM		13.0 m BOOM		16.6 m BOOM	
	Boom Angle (deg)	Rated Load (kgs)	Boom Angle (deg)	Rated Load (kgs)	Boom Angle (deg)	Rated Load (kgs)	Boom Angle (deg)	Rated Load (kgs)
1.8	64	16330	75	10560	79	8230	-	-
2.4	57	9760	71	8450	76	7500	80	5850
3.0	48	6890	67	6250	74	5630	77	5130
3.7	38	5050	63	4860	71	4480	75	4180
4.3	25	3700	58	3910	68	3660	73	3420
4.6	0	3260	56	3530	66	3320	72	3140
4.9	-	-	53	3210	65	3070	71	2870
5.5	-	-	48	2700	62	2590	68	2440
6.1	-	-	43	2240	59	2200	66	2100
6.7	-	-	36	1890	55	1890	64	1810
7.3	-	-	29	1610	52	1630	61	1580
7.9	-	-	18	1390	48	1420	59	1380
8.2	-	-	0	1310	46	1320	58	1290
8.5	-	-	-	-	44	1220	56	1210
9.1	-	-	-	-	40	1050	54	1060
9.8	-	-	-	-	36	930	51	920
10.4	-	-	-	-	30	830	48	810
11.0	-	-	-	-	24	730	45	720
11.6	-	-	-	-	15	640	42	650
11.9	-	-	-	-	0	610	40	600
12.2	-	-	-	-	-	-	39	560
12.8	-	-	-	-	-	-	35	470
13.4	-	-	-	-	-	-	31	390
14.0	-	-	-	-	-	-	26	320
14.6	-	-	-	-	-	-	21	250
15.5	-	-	-	-	-	-	0	170

4.6 m JIB CAPACITIES ON EXTENDED OUTRIGGERS (kgs)					
Main Boom Angle (deg)	Jib Offset Angle				
	0 deg		15 deg		30 deg
	To 13.0 m Main Boom	To 16.6 m Main Boom	To 13.0 m Main Boom	To 16.6 m Main Boom	
80	-	-	2270	2270	1590
75	3450	-	2000	2000	1410
70	2770	-	1770	1770	1240
65	2270	2090	1590	1590	1160
60	1950	1730	1430	1420	1070
55	1730	1460	1290	1260	1000
50	1540	1225	1180	1100	930
45	1380	1020	1090	940	850
40	1270	870	1020	800	780
35	1180	760	980	700	700
30	1090	680	940	625	630
25	1010	610	930	570	-
20	930	565	910	535	-
15	870	550	890	520	-
10	840	535	-	-	-
5	830	530	-	-	-
0	825	530	-	-	-

- The rated loads are the maximum lift capacities as determined by operating radius, boom length and boom angle. The operating radius is the horizontal distance from a projection of the axis of rotation to the supporting surface, before loading, to the center of vertical hoist line or tackle with load applied.
- The rated loads shown on outriggers do not exceed 80% of actual tipping. The rated loads shown on rubber do not exceed 75% of actual tipping. These ratings are based on freely suspended loads with the crane leveled, standing on a firm, uniform supporting surface. Practical working loads depend on supporting surface, operating radius and other factors affecting stability. Hazardous surroundings, climatic conditions, experience of personnel and proper handling must all be taken into account by the operator.
- The weights of all load handling devices, such as hooks, hook blocks, slings, etc., except the hoist rope, shall be considered as part of the load. See above.
- Ratings on outriggers are for either outriggers fully extended and down or fully retracted and down. Ratings for outriggers fully retracted and down will apply for any intermediate outrigger setting.
- Ratings on rubber depend on tire capacity, condition of tires and proper inflation pressure (8.3 bar). Loads on rubber may be transported at a maximum speed of 1.4 km/h on a smooth hard level surface with boom retracted to the shortest length possible and centered over front. Do not use jib with crane on rubber.
- For operating radius not shown, use load rating of next larger radius.
- The maximum combined total boom and deck load is 7 264 kgs. The maximum deck load only is 9 080 kgs.
- Do not induce any external side loads to boom or jib.

MAXIMUM PERMISSIBLE SINGLE LINE PULL = 4 080 kgs

WIRE ROPE: 13 mm dia. 10 x 19 EIPS IWRC BRIGHT
Min. req'd breaking strength = 15 710 kgs

THIS CHART IS ONLY A GUIDE AND SHOULD NOT BE USED TO OPERATE THE CRANE. The individual crane's load chart, operating instructions and other instructional plates must be read and understood prior to operating the crane.

YB5500 Series

Regional Headquarters

Americas

Manitowoc, Wisconsin, USA

Tel: +1 920 684 6621

Fax: +1 920 683 6278

Shady Grove, Pennsylvania, USA

Tel: +1 717 597 8121

Fax: +1 717 597 4062

Regional Offices

Americas

Brazil

Alphaville

Tel: +55 11 4688 2716

Fax: +55 11 4191 1471

Mexico

Monterrey

Tel: +52 81 8124 0128

Fax: +52 81 8124 0129

Europe, Middle East, Africa

Algeria

Hydra

Tel: +21 3 21 48 1173

Fax: +21 3 21 48 1454

Czech Republic

Netvorice

Tel: +420 317 78 9313

Fax: +420 317 78 9314

France

Baudemont

Tel: +33 385 28 2589

Fax: +33 385 28 0430

Cergy

Tel: +33 130 31 3150

Fax: +33 130 38 6085

Decines

Tel: +33 472 81 5000

Fax: +33 472 81 5010

Germany

Langenfeld

Tel: +49 21 73 8909-0

Fax: +49 21 73 8909 30

Hungary

Budapest

Tel: +36 13 39 8622

Fax: +36 13 39 8622

Italy

Parabiago

Tel: +390 331 49 3311

Fax: +390 331 49 3330

Europe, Middle East, Africa

Ecully, France

Tel: +33 472 18 2020

Fax: +33 472 18 2000

Netherlands

Breda

Tel: +31 76 578 3999

Fax: +31 76 578 3978

Poland

Warsaw

Tel: +48 22 843 3824

Fax: +48 22 843 3471

Portugal

Alfena

Tel: +351 229 69 8840

Fax: +351 229 69 8848

Lisbon

Tel: +351 212 109 340

Fax: +351 212 109 349

Russia

Moscow

Tel: +7 495 641 2359

Fax: +7 495 641 2358

U.A.E.

Dubai

Tel: +971 4 3381 861

Fax: +971 4 3382 343

U. K.

Middlesex

Tel: +44 1 895 43 0053

Fax: +44 1 895 45 9500

Sunderland

Tel: +44 191 522 2000

Fax: +44 191 522 2052

Asia – Pacific

Australia

Melbourne

Tel: +61 3 9 336 1300

Fax: +61 3 9 336 1322

Sydney

Tel: +61 2 9 896 4433

Fax: +61 2 9 896 3122

Asia – Pacific

Shanghai, China

Tel: +86 21 51113579

Fax: +86 21 51113578

Singapore

Tel: +65 6264 1188

Fax: +65 6862 4142

China

Beijing

Tel: +86 10 58674761

Fax: +86 10 58674760

Xi'an

Tel: +86 29 87891465

Fax: +86 29 87884504

Korea

Seoul

Tel: +82 2 508 3361

Fax: +82 2 508 3365

Philippines

Makati City

Tel: +63 2 844 9437

Fax: +63 2 844 4712

Factories

U.S.A.

Manitowoc

Shady Grove

Brazil

Alphaville

France

Charlieu

La Clayette

Moulins

India

Calcutta

Puna

Italy

Niella Tanaro

Germany

Wilhelmshaven

Portugal

Fânzeres

China

Zhangjiagang

