

Technical Data

Specifications & Capacities

RTC 8090

Series II
Telescopic Boom Rough Terrain Crane
90 ton (80.0 metric ton)

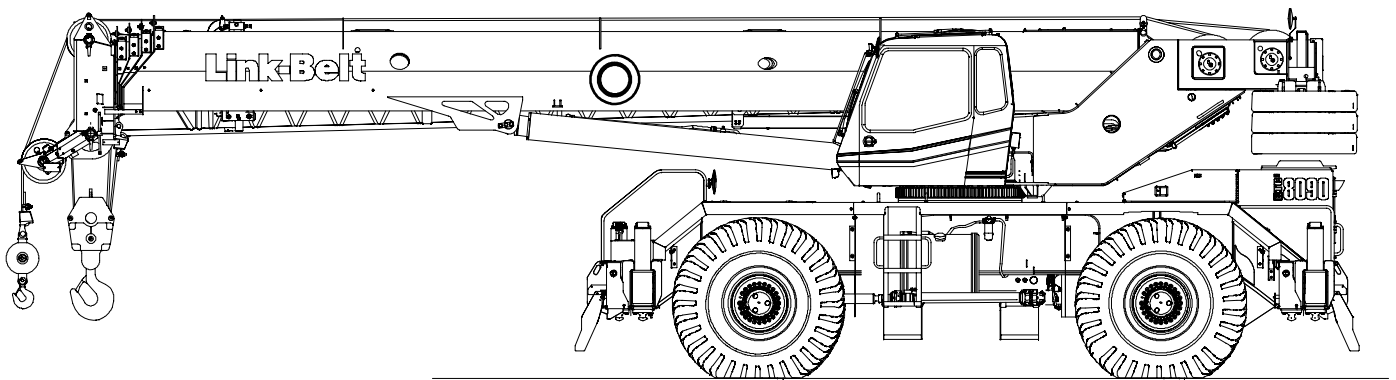

CAUTION: This material is supplied for reference use only. Operator must refer to in-cab Crane Rating Manual and Operator's Manual to determine allowable crane lifting capacities and assembly and operating procedures.

Table Of Contents

Boom, Attachments, and Upper Structure	1
Boom	1
Boom Wear Pads	1
Boom Head	1
Boom Elevation	1
Auxiliary Lifting Sheave – Optional	1
Hook Blocks and Balls – Optional	1
Fly – Optional	1
Fly Extensions – Optional	1
Operator's Cab and Controls	1
Swing	2
Electrical	2
Load Hoist System	3
Load Hoist Performance	3
2M Main and Optional Auxiliary Winches	3
Hydraulic System	3
Counterweight	3
Carrier	4
General	4
Outriggers	4
Steering and Axles	4
Suspension	4
Tires and Wheels	4
Brakes	4
Electrical	4
Engine	4
Transmission	4
Carrier Speeds and Gradeability	5
Fuel Tank	5
Hydraulic System	5
Pump Drive	5
Axle Loads	6
General Dimensions	7
Working Range Diagram	8
Boom Extend Modes	9
Main Boom Lift Capacity Charts – Standard	10
19,200 lb Counterweight – Fully Extended Outriggers – 360° Rotation	10
19,200 lb Counterweight – On Tires – Stationary – Boom Centered Over Front Between Tire Tracks	11
19,200 lb Counterweight – On Tires – Pick & Carry (Creep) – Boom Centered Over Front	12
19,200 lb Counterweight – On Tires – Stationary – 360° Rotation	12
28,800 lb Counterweight – Fully Extended Outriggers – 360° Rotation	13

Fly Attachment Lift Capacity Charts – Optional	14
19,200 lb Counterweight – Fully Extended Outriggers – 360° Rotation	14
140 ft Main Boom Length – 2° Fly Offset	14
140 ft Main Boom Length – 15° Fly Offset	14
140 ft Main Boom Length – 30° Fly Offset	15
140 ft Main Boom Length – 45° Fly Offset	15
28,800 lb Counterweight – Fully Extended Outriggers – 360° Rotation	16
140 ft Main Boom Length – 2° Fly Offset	16
140 ft Main Boom Length – 15° Fly Offset	16
140 ft Main Boom Length – 30° Fly Offset	17
140 ft Main Boom Length – 45° Fly Offset	17
Main Boom Lift Capacity Charts – Metric	18
8 709kg Counterweight – Fully Extended Outriggers – 360° Rotation	18
8 709kg Counterweight – On Tires – Stationary – Boom Centered Over Front Between Tire Tracks .	19
8 709kg Counterweight – On Tires – Pick & Carry (Creep) – Boom Centered Over Front	20
8 709kg Counterweight – On Tires – Stationary – 360° Rotation	20
13 064kg Counterweight – Fully Extended Outriggers – 360° Rotation	21
Fly Attachment Lift Capacity Charts – Optional	22
8 709kg Counterweight – Fully Extended Outriggers – 360° Rotation	22
42.67m Main Boom Length – 2° Fly Offset	22
42.67m Main Boom Length – 15° Fly Offset	22
42.67m Main Boom Length – 30° Fly Offset	23
42.67m Main Boom Length – 45° Fly Offset	23
13 064kg Counterweight – Fully Extended Outriggers – 360° Rotation	24
42.67m Main Boom Length – 2° Fly Offset	24
42.67m Main Boom Length – 15° Fly Offset	24
42.67m Main Boom Length – 30° Fly Offset	25
42.67m Main Boom Length – 45° Fly Offset	25

Boom, Attachments, and Upper Structure

■ Boom

Design – Five section, formed construction of extra high tensile steel consisting of one base section and four telescoping sections. The two plate design of each section has multiple longitudinal bends for superior strength. Each telescoping section extends independently by means of one double-acting, single stage hydraulic cylinder with integrated holding valves.

Boom

- 38–140 ft (11.6–42.7m) five section boom
- Three boom extend modes (EM1 through EM3), controlled from the operator's cab, provide superior capacities by varying the extension of the telescoping sections:
 - EM1 extends to 140.0 ft (42.7m)
 - EM2 extends to 115.8 ft (35.3m)
 - EM3 extends to 76.5 ft (23.3m)
- Mechanical boom angle indicator
- Maximum tip height for each extend mode is:
 - EM1 is 149 ft 7 in (45.6m)
 - EM2 is 125 ft 9 in (38.3m)
 - EM3 is 87 ft 1 in (26.5m)

Boom Wear Pads

- Wear pads with Teflon inserts that self-lubricate the boom sections
- Bottom wear pads are universal for all boom sections
- Top wear pads are universal for all boom sections

Boom Head

- Five 16.5 in (41.9cm) root diameter nylon sheaves to handle up to ten parts of line
- Easily removable wire rope guards
- Rope dead end lugs on each side of the boom head
- Boom head is designed for quick-reeve of the hook block

Boom Elevation

- One double acting hydraulic cylinder with integral holding valve
- Boom elevation: -3° to 80°

Auxiliary Lifting Sheave – Optional

- Single 16.5 in (41.9m) root diameter nylon sheave
- Easily removable wire rope guards
- Does not affect erection of the fly or use of the main head sheaves

Hook Blocks and Balls – Optional

- 40 ton (36.3mt) 4 sheave quick-reeve hook block with safety latch
- 60 ton (54.4mt) 4 sheave quick-reeve hook block with safety latch
- 80 ton (72.5mt) 5 sheave quick-reeve hook block with safety latch

- 90 ton (80.0mt) 6 sheave quick-reeve hook block with safety latch
- 8.5 ton (7.7mt) swivel and non-swivel hook balls with safety latch
- 10 ton (9.1mt) swivel and non-swivel hook balls with safety latch

Fly – Optional

- 35 ft (10.7m) one piece lattice fly, stowable, offsettable to 2° , 15° , 30° , and 45° . Maximum tip height is 184 ft 2 in (56.1m).
- 35 ft–58 ft (10.7–17.7m) two piece bi-fold lattice fly, stowable, offsettable to 2° , 15° , 30° , and 45° . Maximum tip height is 206 ft 8 in (63.0m).

Fly Extensions – Optional

- One 16 ft (4.9m) lattice extension, equipped with two 16.5 in (41.9cm) root diameter nylon sheaves, to be mounted between the boom head and fly options. Maximum tip height is 222 ft 4 in (67.8m).
- Two 16 ft (4.9m) lattice extensions, one equipped with two 16.5 in (41.9cm) root diameter nylon sheaves, to be mounted between the boom head and fly options. Maximum tip height is 238 ft 2 in (72.6m). Minimum of 19,200 lb (8 700kg) of counterweight required.

■ Operator's Cab and Controls

Environmental Cab – Fully enclosed, one person cab of galvanneal steel structure with acoustical insulation
Equipped with:

- Tinted and tempered glass windows
- Extra-large fixed front window with windshield wiper and washer
- Swing up roof window with windshield wiper
- Sliding left side door with large fixed window
- Sliding rear and right side windows for ventilation
- Six way adjustable, cushioned seat with seat belt and storage compartment
- Diesel fired warm-water heater with air ducts for front windshield defroster and cab floor
- Defroster fan for the front window
- Bubble level
- Circulating fan
- Adjustable sun visor
- Dome light
- Cup holder
- Fire extinguisher
- Left side viewing mirror
- Two position travel swing lock

Air Conditioning – Optional – Integral with cab heating system utilizing the same ventilation outlets

Engine Dependant Warm-Water Heater – Optional – With air ducts for front windshield defroster and cab floor

Steering Column – Pedestal type with tilt and telescope functions for operator comfort. Column includes the following controls and indicators:

Left and right levers include:

- Horn button
- Turn signal switch
- Driving light switch
- Transmission direction switch

Panel mounted switches for:

- Travel park brake
- Steer mode selector
- 2/4 wheel drive/range selector
- Transmission gear selector
- Hazard flasher

Panel mounted indicator/warning lights for:

- Transmission temperature
- Engine oil pressure
- Travel park brake
- Service brake
- Turn signals
- Rear wheel offset
- Emergency steer – optional

Armrest Controls – Two dual axis hydraulic joystick controllers or optional single axis hydraulic controllers for:

- Swing
- Boom hoist
- Main rear winch
- Auxiliary front winch – optional
- Drum rotation indication
- Drum rotation indicator activation switch
- Winch high/low speed and disable switch(es)
- Warning horn button
- Swing park brake

Outrigger Controls – Hand held control box with umbilical cord gives the operator the freedom to view operation while setting the outriggers.

Foot Controls

- Boom telescope
- Swing brake
- Engine throttle
- Service brake

Right Front Console – Controls and indicators for:

- | | |
|-------------------------------------|---|
| • Engine ignition | • Console dimmer switch |
| • Engine throttle lock | • Bubble level |
| • Function disable | • 12 volt power connection |
| • Front windshield wiper and washer | • Air conditioning – optional |
| • Cab floodlights | • Boom floodlight – optional |
| • Warning horn | • Rotating beacon/Strobe light – optional |
| • Heating controls | • Third wrap indicator – optional |

Cab Instrumentation – Ergonomically positioned, analog instrumentation for crane operation including:

- Engine coolant temperature with warning indicator
- Hydraulic oil temperature with warning indicator
- Fuel level with warning indicator
- Tachometer
- Transmission temperature with warning indicator
- Voltmeter with warning indicator

Rated Capacity Limiter – Microguard graphic audio–visual warning system integrated into the dash with anti–two block and function limiter. Operating data available includes:

- Crane configuration
- Boom length and angle
- Boom head height
- Allowed load and % of allowed load
- Boom angle
- Radius of load
- Actual load
- Operator settable alarms (include):
 - Maximum and minimum boom angles
 - Maximum tip height
 - Maximum boom length
 - Swing left/right positions
 - Operator defined area (imaginary plane)

Integrated Third Wrap Indicator – Optional – Microguard color display visually and audibly warns the operator when the wire rope is on the first/bottom layer and when the wire rope is down to the last three wraps.

Internal RCL Light Bar – Optional – Visually informs the operator when crane is approaching maximum load capacity with a series of green, yellow, and red lights.

External RCL Light Bar – Optional – Visually informs the ground crew when crane is approaching maximum load capacity with a series of green, yellow, and red lights.

■ Swing

Motor/Planetary – Bi–directional hydraulic swing motor mounted to a planetary reducer for 360° continuous smooth swing at 1.9 rpm

Swing Park Brake – 360°, electric over hydraulic, (spring applied/hydraulic released) multi–disc brake mounted on the speed reducer. Operated by a switch from the operator’s cab.

Swing Brake – 360°, foot operated, hydraulic applied disc brake mounted to the speed reducer

Swing Lock – Two–position swing lock (boom over front or rear) operated from the operator’s cab

360° Positive Swing Lock – Optional – Meets New York City requirement

■ Electrical

Swing Alarm – Audio warning device signals when the upper is swinging.

Lights

- Two working lights on front of the cab
- One rotating amber beacon on top of the cab – optional
- One amber strobe beacon on top of the cab – optional
- Boom floodlight – optional

■ Load Hoist System

Load Hoist Performance

Main (Rear) and Auxiliary (Front) Winches – 3/4 in (19mm) Rope										
Layer	Maximum Line Pull		Normal Line Speed		High Line Speed		Layer		Total	
	lb	kg	ft/min	m/min	ft/min	m/min	ft	m	ft	m
1	16,880	7 656.6	172	52.4	341	104.0	114	34.7	114	34.7
2	15,519	7 039.3	187	57.0	371	113.1	124	37.8	238	72.5
3	14,362	6 514.5	202	61.6	401	122.2	134	40.8	372	113.4
4	13,365	6 062.3	217	66.1	430	131.1	144	43.9	516	157.3
5	12,497	5 668.5	232	70.7	460	140.2	154	46.9	670	204.2
6	---	---	---	---	---	---	164	50.0	834	254.2

Wire Rope Application		Diameter		Type	Maximum Permissible Load	
		in	mm		lb	kg
		Main (Rear) Winch	Standard		3/4	19
Optional	3/4		19	18x19 rotation resistant – right regular lay (Type RB)	12,920	5 860.5
Optional	3/4		19	34x7 rotation resistant – right regular lay (Type ZB)	15,600	7 076.2
Auxiliary (Front) Winch	Standard	3/4	19	4 strand, low torque, right regular lay (Type GC)	22,400	10 160.5
	Optional	3/4	19	18x19 rotation resistant – right regular lay (Type RB)	12,920	5 860.5
	Optional	3/4	19	34x7 rotation resistant – right regular lay (Type ZB)	15,600	7 076.2

2M Main and Optional Auxiliary Winches

- Axial piston, full and half displacement (2–speed) motors driven through planetary reduction unit for positive control under all load conditions.
- Grooved lagging
- Power up/down mode of operation
- Hoist drum cable follower – optional
- Drum rotation indicator
- Drum diameter: 16 in (40.6cm)
- Rope length:
 - Main: 730 ft (222.5m)
 - Auxiliary: 500 ft (152.4m) or 730 ft (222.5m)
- Maximum rope storage: 834 ft (254.2m)
- Terminator style socket and wedge

Third wrap indicator – optional – Visually and audibly warns the operator when the wire rope is on the first/bottom layer and when the wire rope is down to the last three wraps

■ Hydraulic System

Counterbalance Valves – All hoist motors, boom extend cylinders, and boom hoist cylinders are equipped with counterbalance valves to provide load lowering and prevents accidental load drop when hydraulic power is suddenly reduced.

Hydraulic Oil Coolers – Two carrier mounted coolers remove heat from the hydraulic oil. One is integral to the engine radiator/charge air cooler and the other is mounted on left side of the carrier.

■ Counterweight

Standard – Total of 19,200 lb (8 709.0kg) counterweight consisting of two counterweights pinned to the upper with capacities for:

- 0 lb (0kg) counterweight*
- 9,600 lb (4 354.5kg) counterweight
- 19,200 lb (8 709.0kg) counterweight

Optional – 9,600 lb (4 354.5kg) in addition to standard counterweight for a total of 28,800 lb (13 063.0kg) counterweight with capacities for:

- 0 lb (0kg) counterweight*
- 9,600 lb (4 354.5kg) counterweight
- 19,200 lb (8 709.0kg) counterweight
- 28,800 lb (13 063.0kg) counterweight*

* Travel speed limited to 5 mph.

Optional – Hydraulic counterweight removal activated by a hand–held controller with enough cable to access the pins on each side of the counterweights.

Carrier

General

- 10 ft 9 in (3.28m) wide
- 14 ft 4 in (4.37m) wheelbase (centerline of first axle to centerline of second axle)

Frame – Box–type, torsion resistant, welded construction made of high tensile steel. Equipped with front and rear towing and tie–down lugs, tow connections, and access ladders.

Outriggers

Boxes – Two double box, front and rear welded to carrier frame

Beams and Jacks – Four single stage beams with Confined Area Lifting Capacities (CALC™) provide selectable outrigger extensions of full, intermediate, and retracted. Hydraulically controlled from the operator's cab with integral check valves.

Pontoons – Four lightweight, quick release, 23.5 x 23.5 in (59.7 x 59.7cm), steel pontoons with contact area of 460 in² (2 968cm²) can be stored for road travel in storage racks on the carrier.

Main Jack Reaction – 108,000 lb (48 988kg) force and 235 psi (1 620kPa) ground bearing pressure

Steering and Axles

Steering – Four independent modes consisting of two wheel front, two wheel rear, four wheel, and crab. Each mode is controlled from the steering wheel and is selected by a switch in the operator's cab.

Drive – Two modes: 4 x 2 and 4 x 4 for off highway travel

Axle 1 – Steered, non–driven for 4 x 2 and steered, driven for 4 x 4

Axle 2 – Steered, driven

Suspension

Front – Rigid mount to the carrier frame

Rear – The rear axle is suspended on the oscillation cylinders with motion of the axle controlled by a four bar linkage system. The oscillation cylinders lockout when the upper structure rotates 2.5° past centerline.

- Hydro–gas rear suspension – optional

Ride Height Adjustment – Suspension can be lowered for transport using a hand–held controller from level ground.

Tires and Wheels

Front and Rear – Four (single) 29.5 x 25–28 ply rating, earthmover type tires on steel disc wheels

- Spare tires and wheels – optional

Brakes

Service – Full hydraulic, dual circuit, disc type brakes on all wheel ends

Parking/Emergency – Spring applied type, acting on front axle

Electrical

Two batteries provide 12 volt starting and operation

Lights

- Front lighting includes two main headlights and two parking/directional indicators.
- Side lighting includes two parking/directional indicators per side.
- Rear lighting includes two parking/directional indicators, two parking/brake lights, and two reversing lights.
- Other equipment includes hazard/warning system, cab light, instrument panel light, and signal horn.

Engine

Specification	CAT C6.6
Numbers of Cylinders	6
Cycle	4
Bore and Stroke: inch (mm)	4.13 x 5.00 (105 x 127)
Piston Displacement: in ³ (L)	403 (6.6)
Max. Brake Horsepower: hp (kW)	235 (175.2) @ 2,000 rpm
Peak Torque: ft lb (Nm)	727 (986) @ 1,400 rpm
Alternator: volts – amps	12 – 150
Crankcase Capacity: qt (L)	18.4 (17.4)
• Mechanically driven fan and thermostatically controlled radiator	

Transmission

Powershift – Three speed with high/low range for 6 forward and 6 reverse gears. Front axle disconnect for two or four wheel drive. Front axle disconnects in high range.

■ Carrier Speeds and Gradeability

Spicer		Ratio	Speed		Gradeability (@ stall)
Gear			mph	km/h	% Grade
6th	Forward & Reverse 2WD/Hi	0.82	19.8	31.9	2.4
5th		2.25	8.1	13.0	10.2
4th		4.67	4.0	6.4	23.8
3rd	Forward & Reverse 4WD/Low	2.4	7.6	12.3	11.0
2nd		6.54	2.9	4.7	35.2
1st		13.6	1.4	2.3	101.2

Based on a gross vehicle weight of 105,500 lb (47 854kg).

Crane operating angle must not exceed 35° (77% grade).

■ Fuel Tank

One 75 gallon (283.9L) capacity tank

■ Hydraulic System

All functions are hydraulically powered allowing positive precise control with independent or simultaneous operation of all functions.

Main Pumps

- One two section fixed displacement gear pump for the front/rear winches and boom hoist/telescope circuits.
- One two section fixed displacement gear pump for the swing/steering and outrigger/telescope/service brake/oscillation circuits.
- One single section gear pump for an additional supply to the front/rear winch circuit.
- Combined pump capacity of 138 gpm (522.4Lpm)

Hydraulic Reservoir – 153 gal (579.2L) capacity equipped with sight level gauge. Diffusers built in for deaeration.

Filtration – One 10 micron, full flow return line filter. Accessible for easy filter replacement.

■ Pump Drive

One pump is mounted on the engine with the rest being transmission mounted. All pumps are mechanically driven by the diesel engine.

- Front/rear winches and boom hoist/telescope pump can be disconnected with a manual pump disconnect to aid in cold weather starting – optional.

Axle Loads

Base crane with zero counterweight and full tank of fuel	Gross Vehicle Weight ⁽¹⁾		Upper Facing Front				Upper Facing Rear			
			Front Axles		Rear Axles		Front Axles		Rear Axles	
	lb	kg	lb	kg	lb	kg	lb	kg	lb	kg
	79,919	36 251	51,085	23 172	28,834	13 079	22,585	10 245	57,334	26 007
Pintle hook, front	13	6	17	8	-5	-2	17	8	-5	-2
Pintle hook, rear	13	6	-5	-2	18	8	-5	-2	18	8
Rear steer indicator	6	3	0	0	6	3	0	0	6	3
Hydro-gas suspension	56	25	20	9	36	16	20	9	36	16
Pump disconnect	39	18	7	3	32	15	7	3	32	15
Operator in cab	250	113	140	64	110	50	110	50	140	64
Hoist drum follower – main	69	31	-24	-11	93	42	93	42	-24	-11
Auxiliary winch with 500 ft (152.4m) wire rope	608	276	-74	-34	682	309	682	309	-74	-34
Hoist drum follower – auxiliary	69	31	-6	-3	75	34	75	34	-6	-3
Substitute 500 ft (152.4m) wire rope with 730 ft (222.5m) – auxiliary	288	131	-9	-4	297	135	297	135	-9	-4
Remove 730 ft (222.5m) wire rope from rear (main) winch	-931	-422	203	92	-1,134	-514	-1,134	-514	203	92
Remove 500 ft (152.4m) wire rope from front (auxiliary) winch	-643	-292	21	10	-664	-301	-664	-301	21	10
Counterweight removal	208	94	-62	-28	270	122	270	122	-62	-28
One slab of counterweight on upper	9,600	4 355	-3,356	-1 522	12,956	5 877	12,956	5 877	-3,356	-1 522
Two slabs of counterweight on upper	19,200	8 709	-6,712	-3 045	25,912	11 754	25,912	11 754	-6,712	-3 045
Three slabs of counterweight on upper	28,800	13 064	-10,068	-4 567	38,868	17 630	38,868	17 630	-10,068	-4 567
Emergency steering	255	116	39	18	216	100	216	100	39	18
360° mechanical swing lock	140	64	72	33	68	31	68	31	72	33
Air conditioning	179	81	50	23	129	59	129	59	50	23
Floodlight to front of boom base section	7	3	10	5	-3	-1	-3	-1	10	5
Fly mounting brackets to boom base section for fly options	176	80	239	108	-63	-29	-63	-29	239	108
35 ft (10.67m) offsettable fly – stowed	1,591	722	2,576	1 168	-984	-446	-984	-446	2,576	1 168
35–58 ft (10.67–17.68m) offsettable fly – stowed	2,263	1 026	3,257	1 477	-994	-451	-994	-451	3,257	1 477
Auxiliary lifting sheave	110	50	304	138	-194	-88	-194	-88	304	138
90 ton (80.0mt) 6–sheave hook block at bumper	1,554	705	2,358	1 070	-804	-365	-804	-365	2,358	1 070
80 ton (72.5mt) 5–sheave hook block at bumper	1,406	638	2,134	968	-728	-330	-728	-330	2,134	968
60 ton (54.4mt) 4–sheave hook block at bumper	1,109	503	1,683	763	-574	-260	-574	-260	1,683	763
10 ton (9.1mt) hook ball at bumper	550	250	834	378	-284	-129	-284	-129	834	378
8.5 ton (7.7mt) hook ball at bumper	360	163	546	248	-186	-84	-186	-84	546	248
90 ton (80.0mt) 6–sheave hook block at boom head	1,554	705	4,138	1 877	-2,584	-1 172	-2,584	-1 172	4,138	1 877
80 ton (72.5mt) 5–sheave hook block at boom head	1,406	638	3,744	1 698	-2,338	-1 061	-2,338	-1 061	3,744	1 698
60 ton (54.4mt) 4–sheave hook block at boom head	1,109	503	2,953	1 340	-1,844	-836	-1,844	-836	2,953	1 340
10 ton (9.1mt) hook ball at boom head	550	250	1,465	665	-915	-415	-915	-415	1,465	665
8.5 ton (7.7mt) hook ball at boom head	360	163	959	435	-599	-272	-599	-272	959	435

Tire	Maximum Allowable Axle Load @ 20 mph (32.2km/h)
29.5 x 25 (28–PR)	55,000 lb (24 948kg)

⁽¹⁾ Adjust gross vehicle weight and axle loading according to component weight.

Note: All weights are ±3%.

General Dimensions

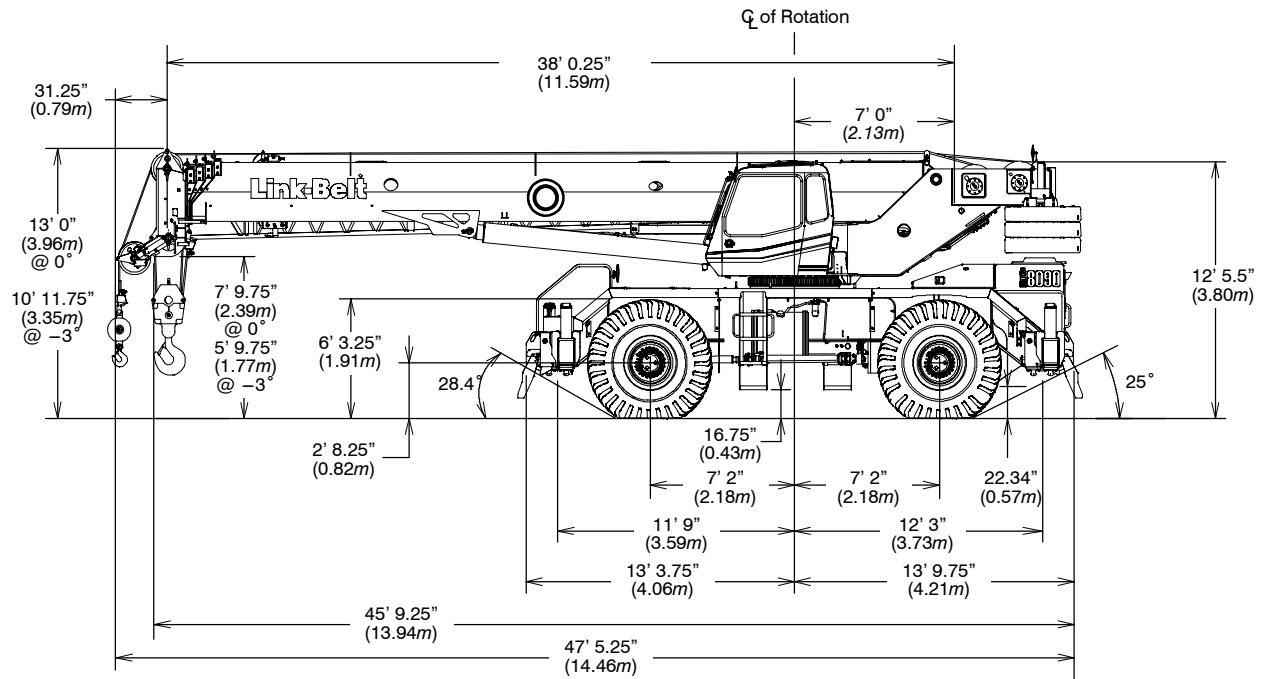

Turning Radius – Front Wheel (4x2) Steering		
	English	Metric
Wall to wall over carrier	48' 3"	14.71m
Wall to wall over boom attachment	60' 1"	18.32m
Curb to curb	46' 8"	13.80m
Centerline of tire	45' 4"	10.28m

Turning Radius – All Wheel (4x4) Steering		
	English	Metric
Wall to wall over carrier	27' 10"	8.49m
Wall to wall over boom attachment	38' 11"	11.86m
Curb to curb	26' 0"	7.91m
Centerline of tire	24' 7"	7.50m

Tail Swing		
	English	Metric
With counterweight	14' 2"	4.32m
Without counterweight	13' 2"	3.97m

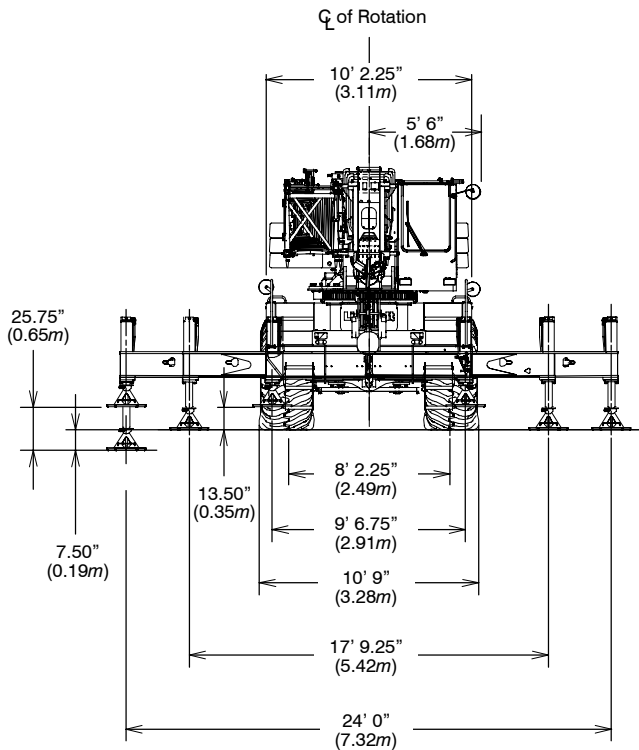

Not To Scale

Working Range Diagram

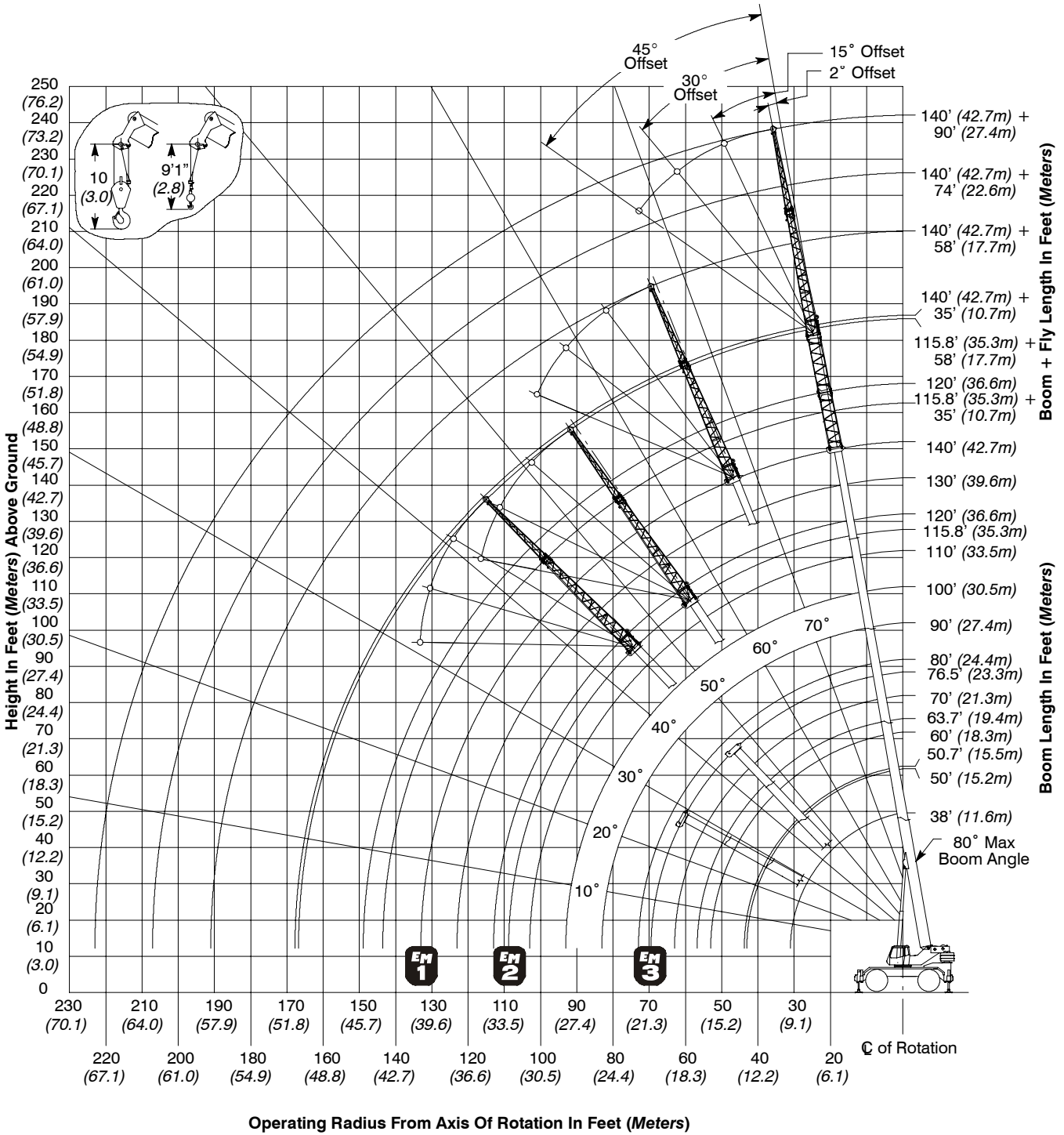

Boom Extend Modes

Boom Length		Section Length			
ft	m	T4	T3	T2	T1
50	15.2	50%			
60	18.3	91%			
70	21.3	100%	31%		
80	24.4	100%	71%		
90	27.4	100%	100%	11%	
100	30.5	100%	100%	49%	
110	33.5	100%	100%	88%	
120	36.6	100%	100%	100%	25%
130	39.6	100%	100%	100%	63%
140	42.7	100%	100%	100%	100%

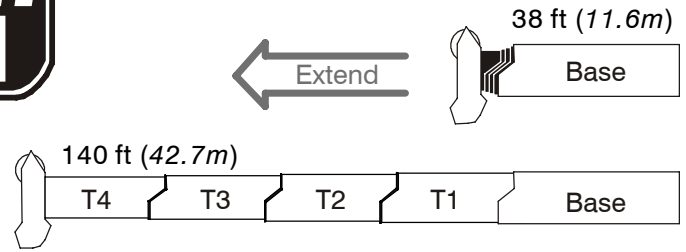

Boom Length		Section Length			
ft	m	T4	T3	T2	T1
50	15.2	0%	48%		
60	18.3	0%	88%		
70	21.3	0%	100%	27%	
80	24.4	0%	100%	65%	
90	27.4	0%	100%	100%	4%
100	30.5	0%	100%	100%	41%
115.8	35.3	0%	100%	100%	100%

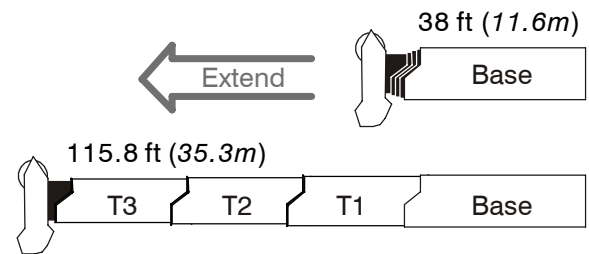

Boom Length		Section Length			
ft	m	T4	T3	T2	T1
50.7	15.5	0%	51%		
63.7	19.4	0%	51%	50%	
76.5	23.3	0%	51%	50%	48%

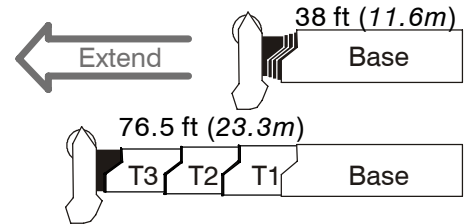

Main Boom Lift Capacity Charts – Standard

19,200 lb Counterweight – Fully Extended Outriggers – 360° Rotation (All Capacities Are Listed In Pounds)												
Radius (ft)	Boom Length (ft)											Radius (ft)
	38	50	60	70	80	90	100	110	120	130	140	
8	180,000*											8
10	160,000	152,000	117,900	70,800								10
12	138,000	138,600	108,800	70,800	85,100							12
15	109,500	111,700	106,500	70,800	78,400	54,200						15
20	80,100	82,400	82,800	63,500	76,500	52,000	49,100	27,200				20
25	62,000	64,300	64,800	54,800	64,300	45,600	45,200	36,300	28,000	26,900		25
30	49,700	52,000	52,600	47,800	52,100	40,600	42,200	35,900	28,000	26,500	24,400	30
35		42,900	44,100	42,500	42,800	36,500	38,300	35,500	28,000	26,300	24,100	35
40		34,300	34,600	35,000	35,100	33,000	34,700	33,400	28,000	26,100	24,000	40
45			28,100	28,400	28,500	28,500	28,100	27,500	26,100	25,900	23,800	45
50			23,200	23,600	23,700	23,800	23,300	23,800	24,100	24,600	23,700	50
55			19,000	20,800	21,300	20,000	21,300	21,700	21,300	20,900	20,500	55
60				18,400	18,800	18,300	18,800	18,700	18,300	17,900	17,600	60
65					16,300	16,500	16,400	16,300	15,900	15,500	15,100	65
70					14,300	14,500	14,400	14,300	13,900	13,500	13,200	70
75						12,800	12,800	12,700	12,300	12,000	11,600	75
80						11,400	11,300	11,200	10,900	10,500	10,200	80
85							10,100	10,000	9,700	9,300	9,000	85
90							9,000	8,900	8,600	8,200	7,900	90
95								8,000	7,700	7,300	7,000	95
100								7,100	6,800	6,500	6,200	100
105								4,200	6,100	5,700	5,400	105
110									5,400	5,100	4,700	110
115										4,500	4,200	115
120										3,900	3,600	120
125											3,100	125
130											2,700	130

* Special Conditions Or Wire Rope Required

This information is not for crane operation. Operator must refer to the in-cab information for crane operation. Rated lifting capacities shown on fully extended outriggers do not exceed 85% of the tipping loads and on tires do not exceed 75% of the tipping loads.

19,200 lb Counterweight – On Tires – Stationary – Boom Centered Over Front Between Tire Tracks (All Capacities Are Listed In Pounds)									
Radius (ft)	Boom Length (ft)								Radius (ft)
	38	50	60	70	80	90	100	110	
15	54,700								15
20	43,300								20
25	33,000	36,200							25
30	23,400	26,500	27,900						30
35		20,300	21,700	22,300					35
40		15,900	17,300	17,900	18,300				40
45			14,000	14,700	15,100	15,200			45
50			11,600	12,200	12,600	12,700	12,700		50
55				10,200	10,700	10,900	10,800	10,700	55
60				8,600	9,000	9,200	9,200	9,100	60
65					7,700	7,900	7,800	7,800	65
70					6,600	6,800	6,700	6,700	70
75						5,800	5,800	5,700	75
80						5,000	4,900	4,900	80
85							4,200	4,200	85
90							3,600	3,500	90
95								3,000	95
100								2,500	100

This information is not for crane operation. Operator must refer to the in-cab information for crane operation. Rated lifting capacities shown on fully extended outriggers do not exceed 85% of the tipping loads and on tires do not exceed 75% of the tipping loads.

19,200 lb Counterweight – On Tires – Pick & Carry (Creep) – Boom Centered Over Front (All Capacities Are Listed In Pounds)									
Radius (ft)	Boom Length (ft)								Radius (ft)
	38	50	60	70	80	90	100	110	
15	52,200								15
20	40,100								20
25	31,700	34,100							25
30	23,400	26,500	27,900						30
35		20,300	21,700	22,300					35
40		15,900	17,300	17,900	18,300				40
45			14,000	14,700	15,100	15,200			45
50			11,600	12,200	12,600	12,700	12,700		50
55				10,200	10,700	10,900	10,800	10,700	55
60				8,600	9,000	9,200	9,200	9,100	60
65					7,700	7,900	7,800	7,800	65
70					6,600	6,800	6,700	6,700	70
75						5,800	5,800	5,700	75
80						5,000	4,900	4,900	80
85							4,200	4,200	85
90							3,600	3,500	90
95								3,000	95
100								2,500	100

19,200 lb Counterweight – On Tires – Stationary – 360° Rotation (All Capacities Are Listed In Pounds)									
Radius (ft)	Boom Length (ft)								Radius (ft)
	38	50	60	70	80	90	100	110	
15	33,700								15
20	20,400								20
25	13,200	15,900							25
30	8,700	11,400	12,700						30
35		8,200	9,500	10,200					35
40		5,900	7,200	7,800	8,200				40
45			5,500	6,100	6,500	6,700			45
50			4,100	4,700	5,100	5,300	5,200		50
55				3,600	4,000	4,100	4,100	4,100	55
60				2,700	3,000	3,200	3,200	3,100	60
65					2,300	2,500	2,400	2,400	65
70					1,600	1,800	1,800	1,700	70
75						1,200	1,200	1,100	75

This information is not for crane operation. Operator must refer to the in-cab information for crane operation. Rated lifting capacities shown on fully extended outriggers do not exceed 85% of the tipping loads and on tires do not exceed 75% of the tipping loads.

28,800 lb Counterweight – Fully Extended Outriggers – 360° Rotation
(All Capacities Are Listed In Pounds)

Radius (ft)	Boom Length (ft)											Radius (ft)	
	38	50	60	70	80	90	100	110	120	130	140		
8	167,200												8
10	155,800	152,000	117,900	70,800									10
12	139,600	138,600	108,800	70,800	85,100								12
15	116,300	118,400	106,500	70,800	78,400	54,200							15
20	85,300	87,500	87,900	63,500	76,500	52,000	49,100	27,200					20
25	66,200	68,500	69,000	54,800	68,500	45,600	45,200	36,300	28,000	26,900			25
30	53,200	55,500	56,100	47,800	55,700	40,600	42,200	35,900	28,000	26,500	24,400		30
35		46,200	46,800	42,500	46,400	36,500	38,300	35,500	28,000	26,300	24,100		35
40		39,600	40,100	38,100	39,300	33,000	34,900	33,400	28,000	26,100	24,000		40
45			34,200	34,500	33,800	30,100	32,100	30,300	26,100	25,900	23,800		45
50			28,500	28,900	28,900	27,600	28,500	27,900	24,100	25,200	23,700		50
55			23,700	24,600	24,700	24,700	24,300	23,800	22,300	23,500	23,600		55
60				21,100	21,200	21,300	20,900	20,400	20,700	21,900	21,700		60
65					18,500	18,500	18,600	18,900	19,300	19,300	18,900		65
70					17,300	16,200	17,500	17,700	17,400	17,000	16,600		70
75						14,900	15,900	15,700	15,400	15,000	14,700		75
80						14,100	14,200	14,100	13,700	13,400	13,000		80
85							12,800	12,700	12,400	12,000	11,700		85
90								11,600	11,500	11,200	10,800	10,500	90
95									10,400	10,100	9,700	9,400	95
100									9,400	9,100	8,700	8,400	100
105									6,300	8,200	7,900	7,600	105
110										7,400	7,100	6,800	110
115											6,400	6,100	115
120											5,800	5,500	120
125												4,900	125
130												4,400	130

This information is not for crane operation. Operator must refer to the in-cab information for crane operation. Rated lifting capacities shown on fully extended outriggers do not exceed 85% of the tipping loads and on tires do not exceed 75% of the tipping loads.

Fly Attachment Lift Capacity Charts – Optional

19,200 lb Counterweight – Fully Extended Outriggers – 360° Rotation (All Capacities Are Listed In Pounds)									
140 ft Main Boom Length 2° Fly Offset					140 ft Main Boom Length 15° Fly Offset				
Radius (ft)	Fly Length (ft)				Radius (ft)	Fly Length (ft)			
	35	58	74	90		35	58	74	90
35	12,100				35				
40	12,100				40				
45	12,100	8,500			45	11,500			
50	12,100	8,400	6,600		50	11,400			
55	12,100	8,300	6,600	5,200	55	11,200			
60	12,100	8,100	6,600	5,200	60	11,000	7,200		
65	11,900	8,000	6,600	5,200	65	10,800	7,000	6,300	
70	11,700	7,800	6,600	5,200	70	10,600	6,800	6,000	4,800
75	11,500	7,700	6,600	5,100	75	10,400	6,700	5,700	4,500
80	10,900	7,500	6,400	4,800	80	10,200	6,500	5,400	4,200
85	9,600	7,300	6,000	4,500	85	10,000	6,300	5,100	4,000
90	8,500	7,100	5,700	4,200	90	9,100	6,200	4,900	3,700
95	7,600	6,900	5,400	4,000	95	8,100	6,000	4,600	3,500
100	6,700	6,700	5,100	3,700	100	7,200	5,900	4,400	3,300
105	6,000	6,400	4,900	3,500	105	6,400	5,700	4,200	3,100
110	5,300	5,700	4,700	3,300	110	5,700	5,600	4,100	3,000
115	4,700	5,100	4,500	3,200	115	5,000	5,500	3,900	2,800
120	4,100	4,500	4,300	3,000	120	4,400	5,100	3,700	2,700
125	3,600	4,000	3,900	2,800	125	3,900	4,500	3,600	2,500
130	3,100	3,600	3,500	2,700	130	3,400	4,000	3,500	2,400
135	2,700	3,100	3,000	2,500	135	3,000	3,600	3,300	2,300
140	2,300	2,700	2,600	2,400	140	2,500	3,100	3,000	2,200
145	2,000	2,400	2,300	2,200	145	2,200	2,700	2,600	2,100
150	1,700	2,000	1,900	1,900	150	1,800	2,400	2,200	2,000
155	1,400	1,700	1,600	1,600	155	1,500	2,000	1,900	1,900
160	1,100	1,400	1,300	1,300	160	1,200	1,700	1,600	1,600
165	800	1,200	1,000	1,000	165	900	1,400	1,300	1,300
170		900			170		1,100	1,000	1,000

This information is not for crane operation. Operator must refer to the in-cab information for crane operation. Rated lifting capacities shown on fully extended outriggers do not exceed 85% of the tipping loads and on tires do not exceed 75% of the tipping loads.

19,200 lb Counterweight – Fully Extended Outriggers – 360° Rotation (All Capacities Are Listed In Pounds)									
140 ft Main Boom Length 30° Fly Offset					140 ft Main Boom Length 45° Fly Offset				
Radius (ft)	Fly Length (ft)				Radius (ft)	Fly Length (ft)			
	35	58	74	90		35	58	74	90
40					40				
45					45				
50					50				
55	10,000				55				
60	9,800				60				
65	9,700				65	8,800			
70	9,500				70	8,800			
75	9,400	5,700	4,600		75	8,700			
80	9,200	5,600	4,400	3,600	80	8,600			
85	9,100	5,500	4,200	3,400	85	8,600	4,900	3,700	
90	9,000	5,400	4,100	3,200	90	8,500	4,900	3,500	2,900
95	8,500	5,300	3,900	3,000	95	8,400	4,800	3,400	2,700
100	7,600	5,200	3,700	2,900	100	7,900	4,800	3,300	2,600
105	6,800	5,100	3,600	2,700	105	7,000	4,700	3,200	2,400
110	6,000	5,000	3,500	2,600	110	6,200	4,700	3,100	2,300
115	5,300	4,900	3,300	2,400	115	5,500	4,700	3,000	2,200
120	4,700	4,800	3,200	2,300	120	4,900	4,600	2,900	2,100
125	4,100	4,700	3,100	2,200	125	4,300	4,500	2,800	2,000
130	3,600	4,500	3,000	2,100	130	3,700	4,400	2,700	1,900
135	3,100	4,000	2,900	2,000	135	3,200	4,300	2,700	1,800
140	2,700	3,500	2,800	1,900	140		3,700	2,600	1,800
145	2,300	3,100	2,800	1,800	145		3,300	2,600	1,700
150	1,900	2,700	2,600	1,700	150		2,800	2,500	1,600
155	1,500	2,300	2,200	1,700	155		2,400	2,400	1,600
160		1,900	1,900	1,600	160		2,000	2,100	1,500
165		1,600	1,500	1,500	165			1,700	1,500
170		1,300	1,200	1,300	170			1,300	1,400
175		900	900	1,000	175				1,100

This information is not for crane operation. Operator must refer to the in-cab information for crane operation. Rated lifting capacities shown on fully extended outriggers do not exceed 85% of the tipping loads and on tires do not exceed 75% of the tipping loads.

28,800 lb Counterweight – Fully Extended Outriggers – 360° Rotation (All Capacities Are Listed In Pounds)									
140 ft Main Boom Length 2° Fly Offset					140 ft Main Boom Length 15° Fly Offset				
Radius (ft)	Fly Length (ft)				Radius (ft)	Fly Length (ft)			
	35	58	74	90		35	58	74	90
35	12,100				35				
40	12,100				40				
45	12,100	8,500			45	11,500			
50	12,100	8,400	6,600		50	11,400			
55	12,100	8,300	6,600	5,200	55	11,200			
60	12,100	8,100	6,600	5,200	60	11,000	7,200		
65	11,900	8,000	6,600	5,200	65	10,800	7,000	6,300	
70	11,700	7,800	6,600	5,200	70	10,600	6,800	6,000	4,800
75	11,500	7,700	6,600	5,100	75	10,400	6,700	5,700	4,500
80	11,300	7,500	6,400	4,800	80	10,200	6,500	5,400	4,200
85	11,000	7,300	6,000	4,500	85	10,000	6,300	5,100	4,000
90	10,500	7,100	5,700	4,200	90	9,700	6,200	4,900	3,700
95	10,000	6,900	5,400	4,000	95	9,400	6,000	4,600	3,500
100	9,000	6,700	5,100	3,700	100	9,000	5,900	4,400	3,300
105	8,100	6,500	4,900	3,500	105	8,500	5,700	4,200	3,100
110	7,300	6,300	4,700	3,300	110	7,700	5,600	4,100	3,000
115	6,600	6,000	4,500	3,200	115	7,000	5,500	3,900	2,800
120	6,000	5,800	4,300	3,000	120	6,300	5,300	3,700	2,700
125	5,400	5,600	4,100	2,800	125	5,700	5,100	3,600	2,500
130	4,800	5,300	3,900	2,700	130	5,100	4,900	3,500	2,400
135	4,400	4,800	3,800	2,500	135	4,600	4,700	3,300	2,300
140	3,900	4,300	3,600	2,400	140	4,100	4,600	3,200	2,200
145	3,500	3,900	3,500	2,300	145	3,700	4,200	3,100	2,100
150	3,100	3,500	3,400	2,200	150	3,300	3,800	3,000	2,000
155	2,700	3,100	3,000	2,100	155	2,900	3,400	2,900	1,900
160	2,400	2,800	2,600	2,000	160	2,500	3,100	2,800	1,800
165	2,100	2,500	2,300	1,900	165	2,200	2,700	2,600	1,700
170		2,200	2,000	1,800	170		2,400	2,300	1,600
175		1,900	1,800	1,700	175		2,100	2,000	1,600
180		1,700	1,500	1,500	180		1,800	1,700	1,500
185		1,400	1,200	1,200	185		1,500	1,400	1,400
190		1,200	1,000	1,000	190			1,200	1,200
195					195			900	900

This information is not for crane operation. Operator must refer to the in-cab information for crane operation. Rated lifting capacities shown on fully extended outriggers do not exceed 85% of the tipping loads and on tires do not exceed 75% of the tipping loads.

28,800 lb Counterweight – Fully Extended Outriggers – 360° Rotation (All Capacities Are Listed In Pounds)									
140 ft Main Boom Length 30° Fly Offset					140 ft Main Boom Length 45° Fly Offset				
Radius (ft)	Fly Length (ft)				Radius (ft)	Fly Length (ft)			
	35	58	74	90		35	58	74	90
40					40				
45					45				
50					50				
55	10,000				55				
60	9,800				60				
65	9,700				65	8,800			
70	9,500				70	8,800			
75	9,400	5,700	4,600		75	8,700			
80	9,200	5,600	4,400	3,600	80	8,600			
85	9,100	5,500	4,200	3,400	85	8,600	4,900	3,700	
90	9,000	5,400	4,100	3,200	90	8,500	4,900	3,500	2,900
95	8,800	5,300	3,900	3,000	95	8,400	4,800	3,400	2,700
100	8,500	5,200	3,700	2,900	100	8,200	4,800	3,300	2,600
105	8,200	5,100	3,600	2,700	105	8,000	4,700	3,200	2,400
110	8,000	5,000	3,500	2,600	110	7,700	4,700	3,100	2,300
115	7,300	4,900	3,300	2,400	115	7,500	4,700	3,000	2,200
120	6,600	4,800	3,200	2,300	120	6,700	4,600	2,900	2,100
125	5,900	4,700	3,100	2,200	125	6,000	4,500	2,800	2,000
130	5,300	4,500	3,000	2,100	130	5,400	4,400	2,700	1,900
135	4,800	4,400	2,900	2,000	135	4,800	4,300	2,700	1,800
140	4,300	4,300	2,800	1,900	140		4,200	2,600	1,800
145	3,800	4,200	2,800	1,800	145		4,100	2,600	1,700
150	3,300	4,100	2,700	1,700	150		4,000	2,500	1,600
155	2,900	3,700	2,600	1,700	155		3,800	2,500	1,600
160		3,300	2,600	1,600	160		3,300	2,500	1,500
165		2,900	2,500	1,500	165		2,900	2,500	1,500
170		2,500	2,500	1,500	170			2,500	1,400
175		2,200	2,200	1,400	175			2,200	1,400
180		1,800	1,800	1,400	180				1,400
185			1,500	1,400	185				1,400
190			1,300	1,300	190				1,400
195			1,000	1,100	195				

This information is not for crane operation. Operator must refer to the in-cab information for crane operation. Rated lifting capacities shown on fully extended outriggers do not exceed 85% of the tipping loads and on tires do not exceed 75% of the tipping loads.

Main Boom Lift Capacity Charts – Metric

8 709kg Counterweight – Fully Extended Outriggers – 360° Rotation (All Capacities Are Listed In Kilograms)												
Radius (m)	Boom Length (m)										Radius (m)	
	11.58	15.24	18.29	21.34	24.38	27.43	30.48	33.53	36.58	39.62		42.67
2.5												2.5
3												3
3.5												3.5
4												4
4.5												4.5
5												5
6												6
7												7
8												8
9												9
10												10
12												12
14												14
16												16
18												18
20												20
22												22
24												24
26												26
28												28
30												30
32												32
34												34
36												36
38												38
40												40
42												42

This information is not for crane operation. Operator must refer to the in-cab information for crane operation. Rated lifting capacities shown on fully extended outriggers do not exceed 75% of the tipping loads and on tires do not exceed 65% of the tipping loads.

8 709kg Counterweight – On Tires – Stationary – Boom Centered Over Front Between Tire Tracks (All Capacities Are Listed In Kilograms)								
Radius (m)	Boom Length (m)							Radius (m)
	11.58	15.24	18.29	21.34	24.38	27.43	30.48	
3								3
3.5								3.5
4								4
4.5								4.5
5								5
6								6
7								7
8								8
9								9
10								10
12								12
14								14
16								16
18								18
20								20
22								22
24								24
26								26
28								28

This information is not for crane operation. Operator must refer to the in-cab information for crane operation. Rated lifting capacities shown on fully extended outriggers do not exceed 75% of the tipping loads and on tires do not exceed 65% of the tipping loads.

8 709kg Counterweight – On Tires – Pick & Carry (Creep) – Boom Centered Over Front (All Capacities Are Listed In Kilograms)								
Radius (m)	Boom Length (m)							Radius (m)
	11.58	15.24	18.29	21.34	24.38	27.43	30.48	
3								3
3.5								3.5
4								4
4.5								4.5
5								5
6								6
7								7
8								8
9								9
10								10
12								12
14								14
16								16
18								18
20								20
22								22
24								24
26								26
28								28

8 709kg Counterweight – On Tires – Stationary – 360° Rotation (All Capacities Are Listed In Kilograms)								
Radius (m)	Boom Length (m)							Radius (m)
	11.58	15.24	18.29	21.34	24.38	27.43	30.48	
3								3
3.5								3.5
4								4
4.5								4.5
5								5
6								6
7								7
8								8
9								9
10								10
12								12
14								14
16								16
18								18
20								20

This information is not for crane operation. Operator must refer to the in-cab information for crane operation. Rated lifting capacities shown on fully extended outriggers do not exceed 75% of the tipping loads and on tires do not exceed 65% of the tipping loads.

13 064kg Counterweight – Fully Extended Outriggers – 360° Rotation (All Capacities Are Listed In Kilograms)												
Radius (m)	Boom Length (m)										Radius (m)	
	11.58	15.24	18.29	21.34	24.38	27.43	30.48	33.53	36.58	39.62		42.67
2.5												2.5
3												3
3.5												3.5
4												4
4.5												4.5
5												5
6												6
7												7
8												8
9												9
10												10
12												12
14												14
16												16
18												18
20												20
22												22
24												24
26												26
28												28
30												30
32												32
34												34
36												36
38												38
40												40

This information is not for crane operation. Operator must refer to the in-cab information for crane operation. Rated lifting capacities shown on fully extended outriggers do not exceed 75% of the tipping loads and on tires do not exceed 65% of the tipping loads.

Fly Attachment Lift Capacity Charts – Optional

8 709kg Counterweight – Fully Extended Outriggers – 360° Rotation (All Capacities Are Listed In Kilograms)									
42.67m Main Boom Length 2° Fly Offset					42.67m Main Boom Length 15° Fly Offset				
Radius (m)	Fly Length (m)				Radius (m)	Fly Length (m)			
	10.67	17.68	22.56	27.43		10.67	17.68	22.56	27.43
12					12				
14					14				
16					16				
18					18				
20					20				
22					22				
24					24				
26					26				
28					28				
30					30				
32					32				
34					34				
36					36				
38					38				
40					40				
42					42				
44					44				
46					46				
48					48				

This information is not for crane operation. Operator must refer to the in-cab information for crane operation. Rated lifting capacities shown on fully extended outriggers do not exceed 75% of the tipping loads and on tires do not exceed 65% of the tipping loads.

8 709kg Counterweight – Fully Extended Outriggers – 360° Rotation (All Capacities Are Listed In Kilograms)									
42.67m Main Boom Length 30° Fly Offset					42.67m Main Boom Length 45° Fly Offset				
Radius (m)	Fly Length (m)				Radius (m)	Fly Length (m)			
	10.67	17.68	22.56	27.43		10.67	17.68	22.56	27.43
18					18				
20					20				
22					22				
24					24				
26					26				
28					28				
30					30				
32					32				
34					34				
36					36				
38					38				
40					40				
42					42				
44					44				
46					46				
48					48				

This information is not for crane operation. Operator must refer to the in-cab information for crane operation. Rated lifting capacities shown on fully extended outriggers do not exceed 75% of the tipping loads and on tires do not exceed 65% of the tipping loads.

13 064kg Counterweight – Fully Extended Outriggers – 360° Rotation (All Capacities Are Listed In Kilograms)									
42.67m Main Boom Length 2° Fly Offset					42.67m Main Boom Length 15° Fly Offset				
Radius (m)	Fly Length (m)				Radius (m)	Fly Length (m)			
	10.67	17.68	22.56	27.43		10.67	17.68	22.56	27.43
12					12				
14					14				
16					16				
18					18				
20					20				
22					22				
24					24				
26					26				
28					28				
30					30				
32					32				
34					34				
36					36				
38					38				
40					40				
42					42				
44					44				
46					46				
48					48				
50					50				
52					52				
54					54				
56					56				
58					58				
60					60				

This information is not for crane operation. Operator must refer to the in-cab information for crane operation. Rated lifting capacities shown on fully extended outriggers do not exceed 75% of the tipping loads and on tires do not exceed 65% of the tipping loads.

13 064kg Counterweight – Fully Extended Outriggers – 360° Rotation (All Capacities Are Listed In Kilograms)									
42.67m Main Boom Length 30° Fly Offset					42.67m Main Boom Length 45° Fly Offset				
Radius (m)	Fly Length (m)				Radius (m)	Fly Length (m)			
	10.67	17.68	22.56	27.43		10.67	17.68	22.56	27.43
18					18				
20					20				
22					22				
24					24				
26					26				
28					28				
30					30				
32					32				
34					34				
36					36				
38					38				
40					40				
42					42				
44					44				
46					46				
48					48				
50					50				
52					52				
54					54				
56					56				
58					58				
60					60				

This information is not for crane operation. Operator must refer to the in-cab information for crane operation. Rated lifting capacities shown on fully extended outriggers do not exceed 75% of the tipping loads and on tires do not exceed 65% of the tipping loads.

This Page Intentionally Blank

This Page Intentionally Blank

Link-Belt Construction Equipment Company Lexington, Kentucky www.linkbelt.com

®Link-Belt is a registered trademark. Copyright 2007. We are constantly improving our products and therefore reserve the right to change designs and specifications.